

Gas-fired wall-mounted condensing boiler
 31 to 370 MBH / 9 to 105 kW
 Multi-boiler installation 320 to 1480 MBH/



Technical Data Manual

Model Nos. and pricing: see Price List



Vitodens 200-W

WB2B Series

Gas-Fired Wall-Mounted Condensing Boiler
 with modulating MatriX cylinder burner
 for room air independent operation
 (using a direct vent system) or room air
 dependent operation

For Natural Gas and Liquid Propane Gas
 Heating input 31 to 370 MBH
 for NG and LPG 9 to 105 kW

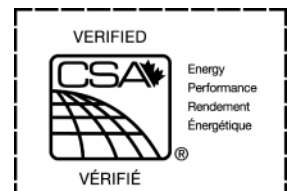

Product Information

VITODENS 200-W

Equipped with the industry's first intelligent combustion management system and powerful control technology, the new generation Vitodens 200-W gas-fired wall-mount condensing boiler delivers unparalleled performance, reliability and comfort.

The benefits at a glance:

- **Best value in its class** with new industry-leading technology and the most standard features.
- **Highest Efficiency** up to 98% at full modulation and up to 96.1% A.F.U.E. CSA thermal efficiency rating to ANSI Z.21.13/CSA 4.9 of 94.5% (for model WB2B 105 only). Energy Star and the CSA Energy Performance are not applicable for model WB2B 105.
- **Compact, Esthetic Product Design** and zero clearance to combustibles.
- **Extremely Quiet Operation**; quieter than most refrigerators.
- **True High-Altitude Operation** up to 10,000 ft. / 3,000 m with simple electronic adjustment.
- **Lasting performance** with industry-leading Viessmann made SA240 316 Ti stainless steel Inox-Radial heat exchanger constructed to CSA B51 and ASME Section IV.
- **Low Emission Combustion** with Viessmann made stainless steel MatriX cylinder burner. Factory calibrated.
- **Fast Installation and Reduced Maintenance** with Lambda Pro, industry-first intelligent combustion management system: Adjusts automatically to gas type and quality. No fuel conversion kit required.
- **Powerful and User-friendly**
Viessmann Vitotronic on-board multi-function outdoor reset boiler and system control for multi-temperature space and DHW heating.
- **Expanded Application Range** with increased capacity up to 370 MBH. Multi-boiler installation up to 1480 MBH with up to 4 boilers (models WB2B 45, 60, 80, 105).
- **Greater Venting Flexibility** with increased vent length (up to 180 ft. / 55 m) and multiple venting options.
 - Horizontal or vertical sealed combustion coaxial venting (factory supplied).
 - Horizontal, vertical or hybrid sealed combustion double-pipe venting (field supplied).
 - Horizontal or vertical single-wall venting (field supplied).

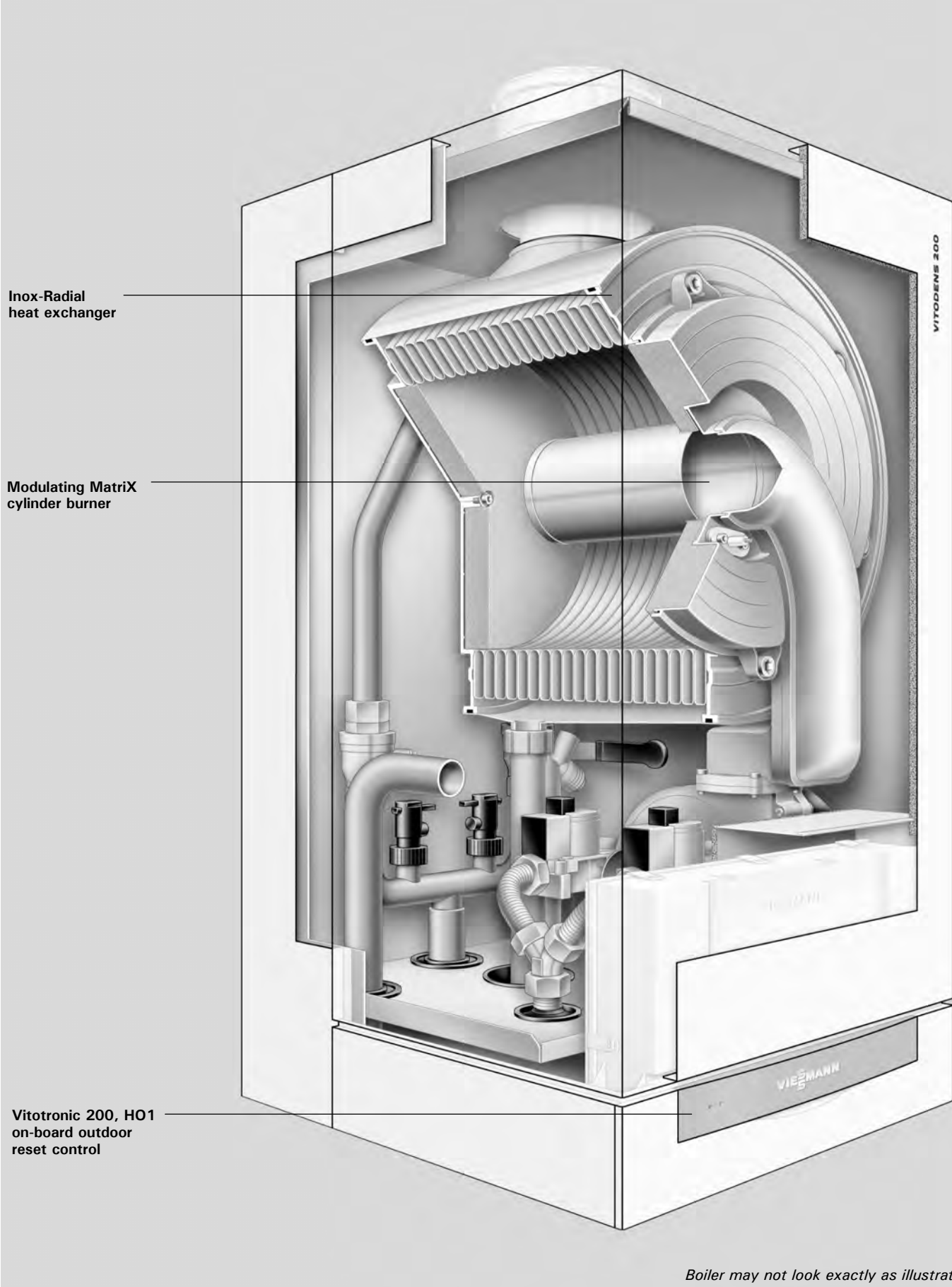

5369 295 v1.4

Boiler may not look exactly as illustrated.

Technical Data

Table 1.

Boiler Model	Model No. WB2B-	19	26	35	45	60	80	105* ^A	
Natural gas / Liquid propane gas									
CSA input	MBH	31-67	31-93	31-125	60-160	60-212	104-285	104-370	
	kW	9-20	9-27	9-37	17-47	17-62	30-83	30-108	
CSA output/DOE*¹	MBH	28-61	28-85	28-114	55-146	55-194	95-260	98-350	
heating capacity	kW	8-18	8-25	8-33	16-43	16-57	28-76	29-103	
Net I = B = R rating*²	MBH	53	74	99	127	169	226	304	
Heat exchanger surface area	ft. ²	10.23	10.23	10.23	15.76	15.76	28.88	28.88	
	m ²	0.95	0.95	0.95	1.46	1.46	2.68	2.68	
Min. gas supply pressure									
Natural gas	"w.c.	4	4	4	4	4	4	4	
Liquid propane gas	"w.c.	10	10	10	10	10	10	10	
Max. gas supply pressure*³									
Natural gas	"w.c.	14	14	14	14	14	14	14	
Liquid propane gas	"w.c.	14	14	14	14	14	14	14	
A.F.U.E.	%	96.1	96.1	96.1	96.1	96.1	96.1		
CSA thermal efficiency ANSI Z21.13/CSA 4.9	%							94.5	
Weight	lbs	102	102	102	155	155	225	225	
	kg	46	46	46	70	70	102	102	
Boiler water content	USG	0.87	0.87	0.87	1.9	1.9	3.4	3.4	
	L	3.3	3.30	3.3	7.2	7.2	12.8	12.8	
Boiler max. flow rate*⁴	GPM	6.2	6.2	6.2	15.4	15.4	35.2	35.2	
	L/h	1400	1400	1400	3500	3500	8000	8000	
Max. operating pressure at 210°F / 99°C	psig	45	45	45	60	60	60	60	
	bar	3	3	3	4	4	4	4	
Boiler water temperature									
– Adjustable high limit (AHL) range									
space heating	°F/	68 to 165 /					68 to 176 /		
(steady state)	°C	20 to 74					20 to 80		
DHW production	°F/	165 /					176 /		
	°C	74					80		
– Fixed high limit (FHL)									
	°F/°C	210/99					210/99		
Boiler connections									
Boiler heating supply and return	NPTM "	¾	¾	¾	1 ¼	1 ¼	1 ¼	1 ¼	
Pressure relief valve	NPTF "	¾	¾	¾	¾	¾	¾	¾	
Drain valve	(male thread)	¾	¾	¾	¾	¾	¾	¾	
Boiler supply/return for indirect-fired DHW storage tank (field supplied)									
	NPT"	¾	¾	¾	1 ¼	1 ¼	1 ¼	1 ¼	
Gas valve connection	NPTF	¾	¾	¾	1	1	1	1	

*^A For high altitude installations (5,000 - 10,000 ft.), the input for model WB2B 105 will have an altitude de-ration of 14% for 5,000 ft. and 28% for 10,000 ft. (average of 2.8% / 1,000 ft.).

*¹ Output based on 140°F / 60°C, 120°F / 49°C system supply/return temperature.

*² Net I=B=R rating based on piping and pick-up allowance of 1.15.

*³ If the gas supply pressure exceeds the maximum gas supply pressure value, a separate gas pressure regulator must be installed upstream of the heating system.

*⁴ See "Typical System Flow Rates" on page 11 in this manual.

Table 1 (continued)

Boiler Model	Model No. WB2B-	19	26	35	45	60	80	105* ⁴
Dimensions								
Overall depth	inches	14	14	14	15	15	21	21
	mm	360	360	360	380	380	530	530
Overall width	inches	17¾	17¾	17¾	19	19	19	19
	mm	450	450	450	480	480	480	480
Overall height	inches	33½	33½	33½	33½	33½	33½	33½
	mm	850	850	850	850	850	850	850
Height with flue gas elbow (accessory)	inches	44	44	44	47¼	47¼	47¼* ⁹	47¼* ⁹
	mm	1116	1116	1116	1200	1200	1200	1200
Flue gas*⁵								
Temperature (at boiler return temperature of 86°F / 30°C)								
– at rated full load	°F/°C	113/45	113/45	113/45	95/35	104/40	95/35	104/40
– at rated partial load	°F/°C	95/35	95/35	95/35	91/33	95/35	91/33	95/35
Temperature (at boiler return temperature of 140°F / 60°C)	°F/°C	154/68	158/70	158/70	149/65	158/70	149/65	158/70
Average condensate flow rate*⁶								
with natural gas and T _S /T _R = 104/86°F / 40/30°C								
	USG/day	2.6-3.4	2.9-3.4	4-4.5	3.7-5	6-7.4	6.6-7.9	9.5-10.5
	L/day	10-12	11-13	15-17	14-19	23-28	25-30	35-40
Condensate connection*⁷								
	hose nozzle							
	Ø in	1	1	1	1	1	1	1
Boiler flue gas connection*⁸								
	Ø							
	in/mm	2 ³ / ₈ /60	2 ³ / ₈ /60	2 ³ / ₈ /60	3¼ /80	3¼ /80	4 ³ / ₈ /110	4 ³ / ₈ /110
Combustion air supply connection (coaxial)*⁸								
	outer							
	Ø in/mm	4/100	4/100	4/100	5/125	5/125	6/150	6/150

*⁴ For high altitude installations (5,000 - 10,000 ft.), the input for model WB2B 105 will have an altitude de-rating of 14% for 5,000 ft. and 28% for 10,000 ft. (average of 2.8% / 1,000 ft.).

*⁵ Measured flue gas temperature with a combustion air temperature of 68°F / 20°C.

*⁶ Based on typical boiler cycles, including partial load conditions.

*⁷ Requires 1" / 25 mm tubing. See the Installation Instructions of the Vitodens 200-W, WB2B for details.

*⁸ For side wall vent installations (coaxial system):

Do **not** exceed max. equivalent length specified in the Installation Instructions of the Vitodens 200-W, WB2B Venting System. A **maximum** of 5 elbows may be installed in the vent system.

Do **not** attempt to common-vent Vitodens 200-W with any other appliance.

Venting material to be supplied by Viessmann **only**; side wall vent installation **must** include Viessmann protective screen!

For details refer to the Installation Instructions for the Vitodens 200-W, WB2B Venting System.

*⁹ Add 2½" / 65 mm for coaxial vent pipe transition adaptor.

► For information regarding other Viessmann System Technology componentry, please reference documentation of respective product.

Dimensional Information

Models WB2B 19, 26, 35

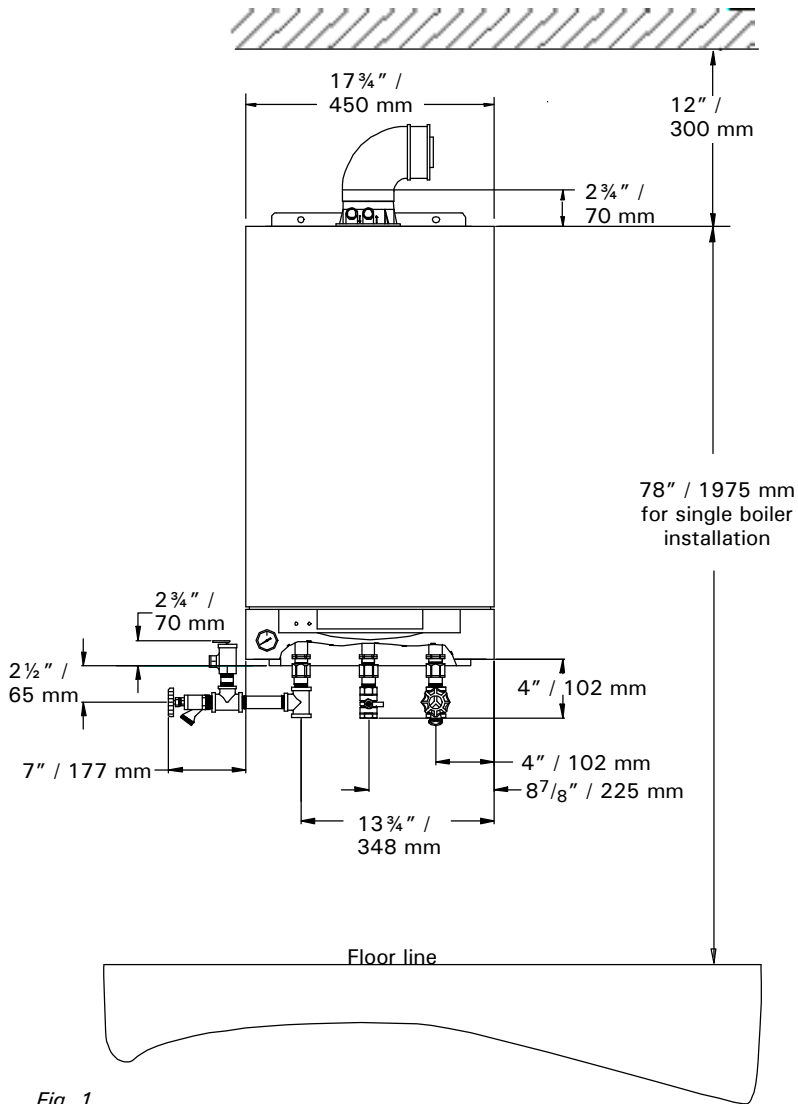

Fig. 1

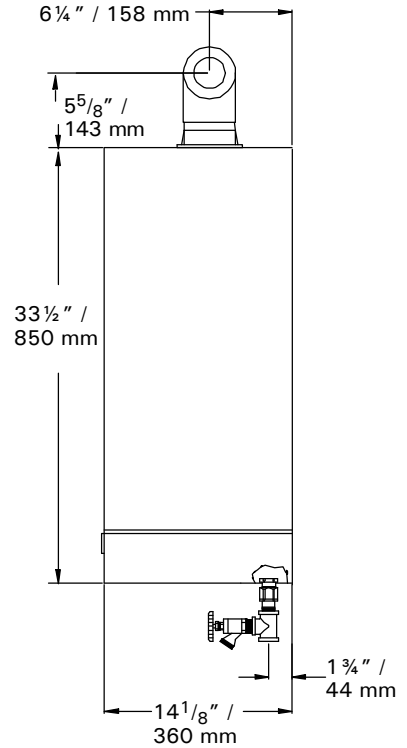

Fig. 2

Legend

- BD Boiler Drain
- BR Boiler Return
- BS Boiler Supply
- AV Air Vent (not shown)
- GC Gas Connection, 3/4" NPT
- PRV Pressure Relief Valve
- BF Boiler Fill
- PG Pressure Gage
- EXT Extension Adaptors, 3/4" NPT
- DR Boiler heating return for domestic hot water production 3/4" (field supplied)
- DS Boiler heating supply for domestic hot water production 3/4" (field supplied)

*1 See page 38 for alternate DHW connection.

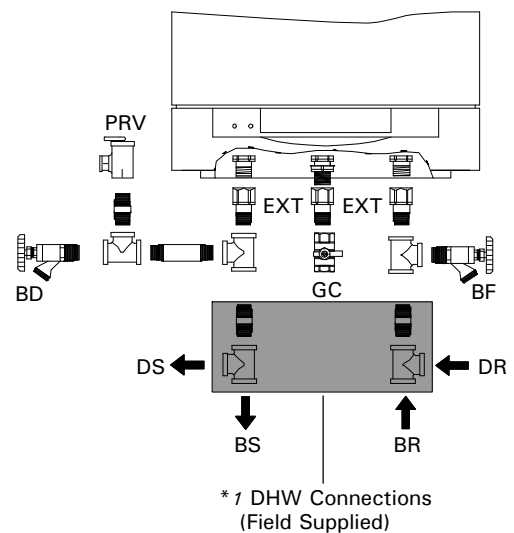

Fig. 3

Models WB2B 45, 60

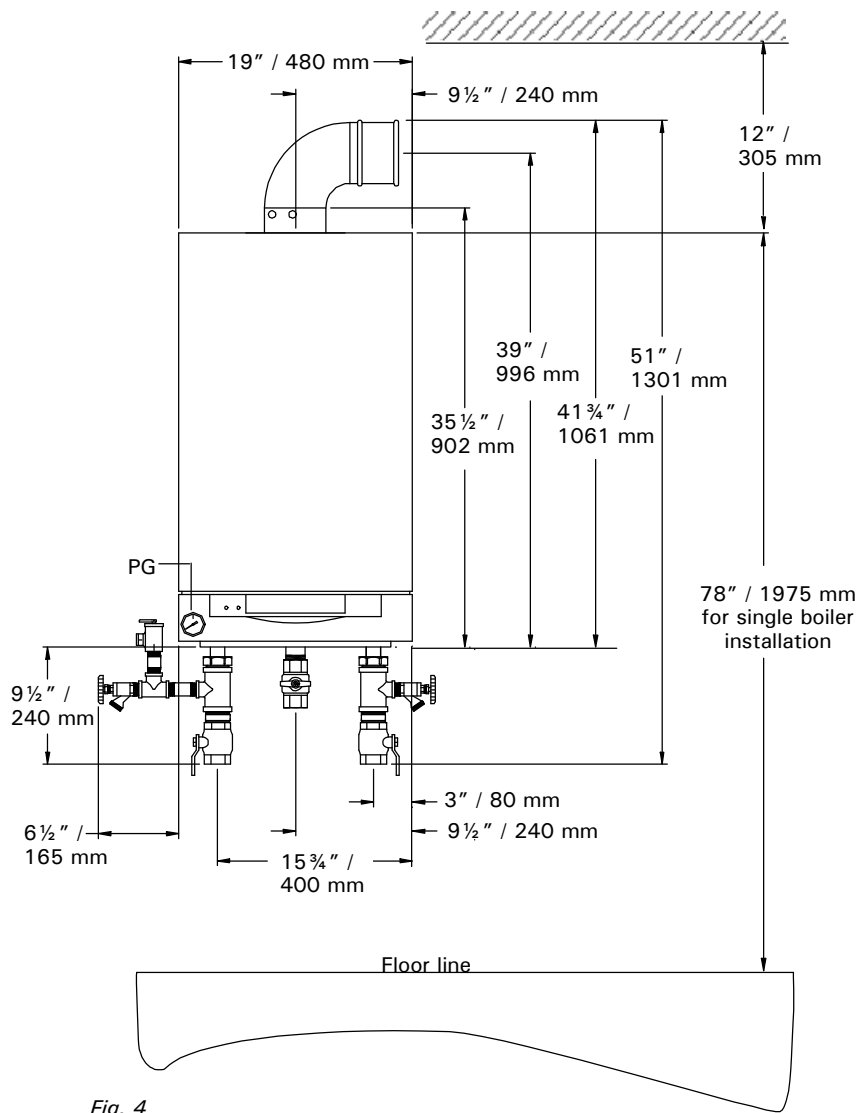

Fig. 4

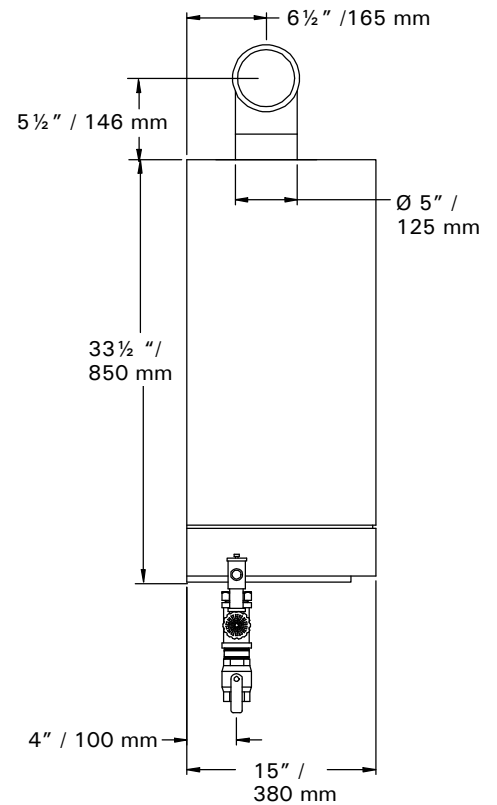

Fig. 5

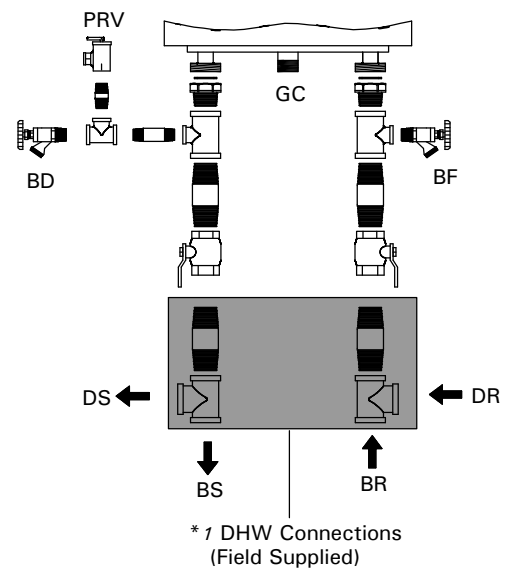

Fig. 6

Legend

- BD Boiler Drain
 - BR Boiler Return
 - BS Boiler Supply
 - AV Air Vent (not shown)
 - GC Gas Connection, 1" NPT
 - PRV Pressure Relief Valve
 - BF Boiler Fill
 - PG Pressure Gage
 - DR Boiler heating return for domestic hot water production 1 1/4" NPT (field supplied)
 - DS Boiler heating supply for domestic hot water production 1 1/4" NPT (field supplied)
- * 1 See page 38 for alternate DHW connection.

Dimensional Information

Models WB2B 80, 105

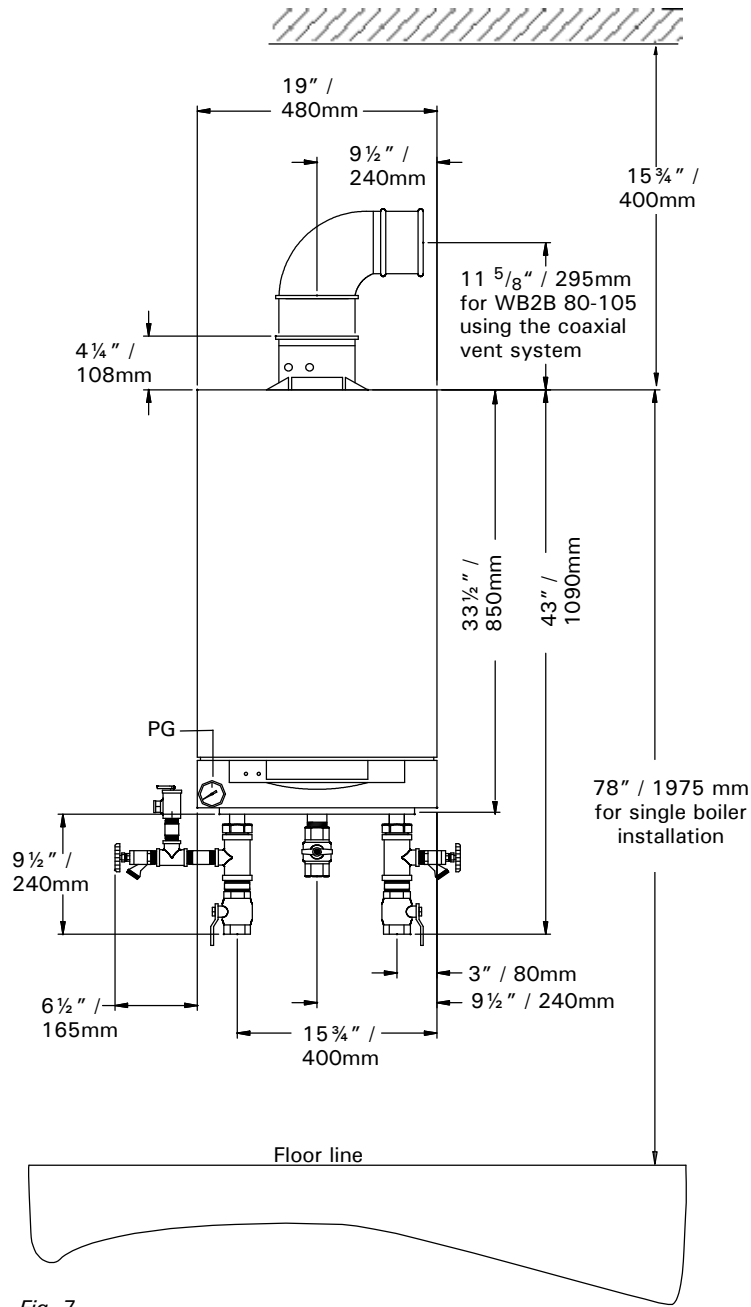

Fig. 7

Legend

- BD Boiler Drain
- BR Boiler Return
- BS Boiler Supply
- GC Gas Connection, 1" NPT
- PRV Pressure Relief Valve
- BF Boiler Fill
- PG Pressure Gage
- DR Boiler heating return for domestic hot water production 1 1/4"
- DS Boiler heating supply for domestic hot water production 1 1/4"
- *1 See page 38 for alternate DHW connection.

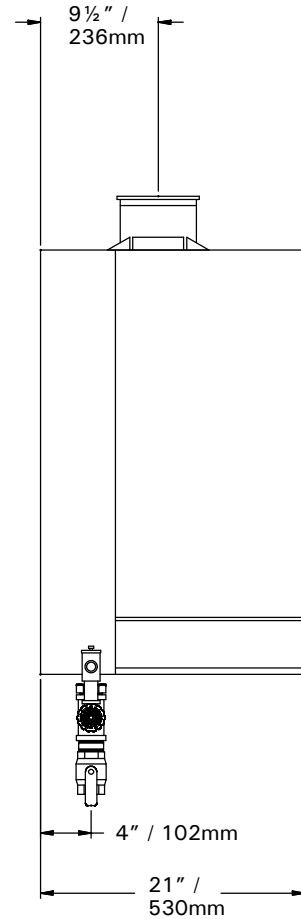

Fig. 8

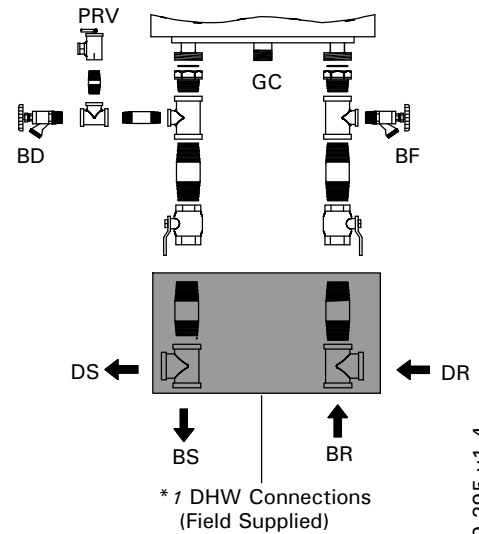

Fig. 9

5369 295 v1.4

Recommended Minimum Service Clearances

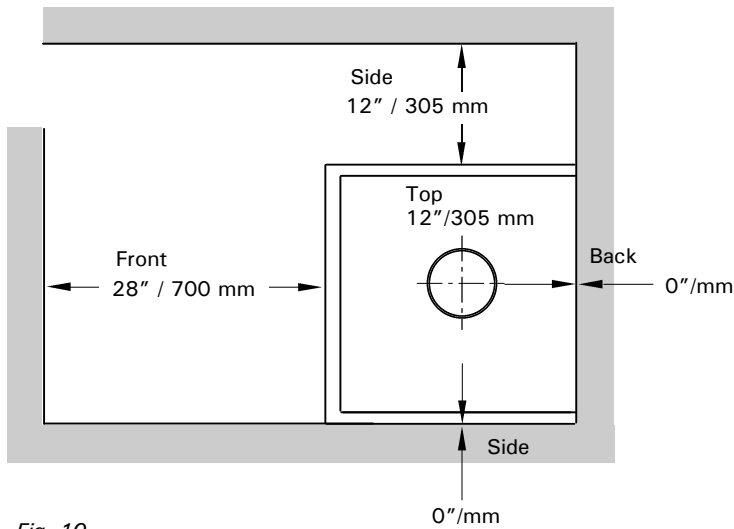

Fig. 10

Minimum Clearances to Combustibles

Top	Front	Rear	Left	Right	Vent pipe*1
0	0 AL, CL	0	0	0	0

AL = Alcove

CL = Closet

*1Refer to the Installation Instructions of the Vitodens 200-W, WB2B Venting System for details.

Please note:

The Vitodens boiler has passed the zero inches vent clearance to combustibles testing requirements dictated by the Harmonized Standard ANSI Z21.13. CSA 4.9.2000 and therefore is listed for zero clearance to combustibles when vented with a single wall special venting system (AL-29-4C material). The zero inches vent clearance to combustibles for the Vitodens boiler supercedes the clearance to combustibles listing that appears on the special venting system label.

Waterside Flow

Waterside Flow (primary circuit)

The Vitodens 200-W, WB2B is designed for closed loop, forced circulation hot water heating systems only.

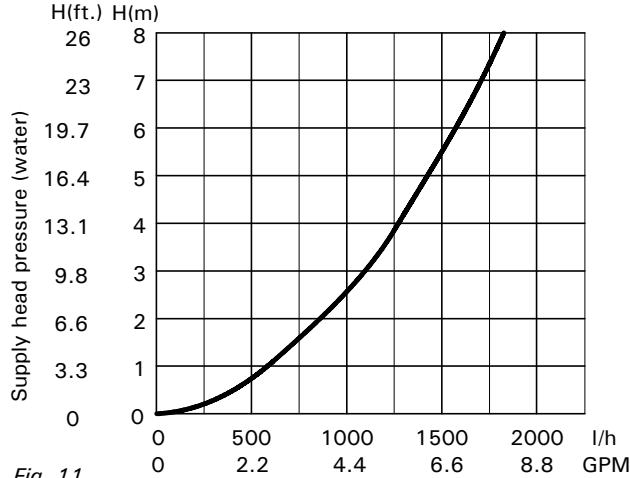

Pressure drop (primary circuit) for Vitodens 200-W, WB2B 19, 26, 35
 For sizing an on-site circulation system.
 Max. flow rate: 1400 L/h / 6.2 GPM

Fig. 11

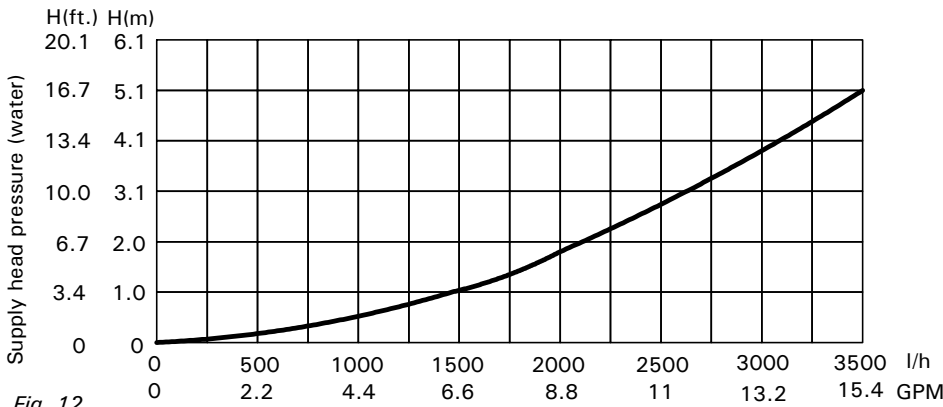

Pressure drop (primary circuit) for Vitodens 200-W, WB2B 45, 60
 For sizing an on-site circulation system.
 Max. flow rate 3500 L/h / 15.4 USGPM

Fig. 12

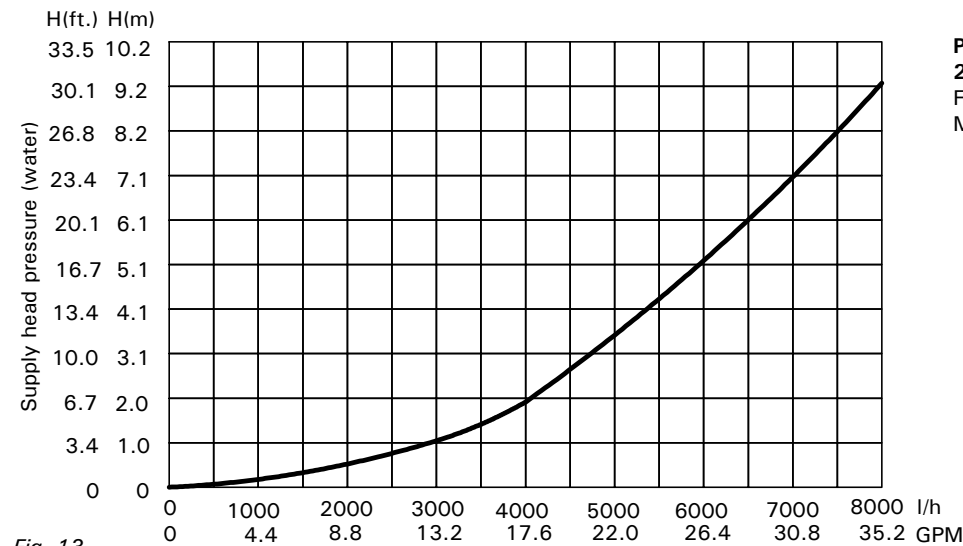

Pressure drop (primary circuit) for Vitodens 200-W, WB2B 80, 105
 For sizing an on-site circulation system.
 Max. flow rate 8000 L/h / 35.2 USGPM

Fig. 13

Use standard friction loss method for pipe sizing. Observe boiler maximum and minimum flow rate limitations. If system flow rate exceeds boiler maximum flow rate (as stated above), falls below the minimum flow rate or if system flow rate is unknown, Viessmann strongly recommends the installation of a low-loss header. An alternative method may be used, such as primary secondary piping using closely spaced tees. A low-loss header offers additional benefits not provided by a pair of closely spaced tees. Viessmann therefore strongly recommends and prefers the use of a low-loss header over closely spaced tees. See page 13 for low-loss header information.

Typical System Flow Rates

Table 2.

Model	WB2B	19	26	35
Δt for NG/LPG				
Output (NG/LPG) Btu/h				
20°F rise (GPM)		6.1	8.5	11.4
25°F rise (GPM)		4.9	6.8	9.1
30°F rise (GPM)		4.1	5.7	7.6
35°F rise (GPM)		3.5	4.9	6.5
40°F rise (GPM)		3.1	4.3	5.7

Boiler max. flow rate 1400 L/h (6.2 GPM)

Table 3.

Model	WB2B	45	60
Δt for NG/LPG			
Output (NG/LPG) Btu/h			
20°F rise (GPM)		14.6	19.4
25°F rise (GPM)		11.7	15.5
30°F rise (GPM)		9.7	12.9
35°F rise (GPM)		8.3	11.1
40°F rise (GPM)		7.3	9.7

Boiler max. flow rate 3500 L/h (15.4 GPM)

Table 4.

Model	WB2B	80	105
Δt for NG/LPG			
Output (NG/LPG) Btu/h			
20°F rise (GPM)		26.0	35.0
25°F rise (GPM)		20.8	28.0
30°F rise (GPM)		17.3	23.3
35°F rise (GPM)		14.9	20.0
40°F rise (GPM)		13.0	17.5

Boiler max. flow rate 8000 L/h (35.2 GPM)

Use standard friction loss method for pipe sizing. Observe boiler maximum and minimum flow rate limitations. If system flow rate exceeds boiler maximum flow rate (as stated above), falls below the minimum flow rate or if system flow rate is unknown, Viessmann strongly recommends the installation of a low-loss header. Once the low-loss header is connected, the built-in low-loss header logic of the Vitodens 200-W boiler ensures the required ΔT across the system through the sensory communication between the low-loss header and the boiler. See page 13 for low-loss header information.

Pump Information

Heating Circuit / Boiler Pumps

Viessmann offers a variety of Grundfos heating circuit / boiler pumps which meet typical Vitodens system installation requirements (see "Heating circuit pump (field supplied)" or "Boiler pump (field supplied)" in the Installation Examples starting on page 29). See tables below for recommended pumps. Refer to the graphs on page 10 for the proper waterside boiler friction loss calculations.

IMPORTANT

Pump selection must be based on accurate system flow and pressure drop calculations (incl. DHW sizing).

The following pumps have been selected based on boiler heat exchanger head loss and boiler piping to a low-loss header. Before using the following pumps for a DHW tank application, find out the proper pressure drop through the tank, the required temperature difference through the coil and system piping head loss of the domestic hot water.

Table 5.

Model	WB2B	19	26	35
Flow rate				
20 °F Δt		6.1	8.5	11.4
25 °F Δt		4.9	6.8	9.1
30 °F Δt		4.1	5.7	7.6
35 °F Δt		3.5	4.9	6.5
40 °F Δt		3.1	4.3	5.7
Flow limitation L/h / GPM		1400 / 6.2		
Recommended boiler pumps		Grundfos 15-58 (3-speed) Taco OOR Wilo Star S 21 FX		

Table 6.

Model	WB2B 45	Flow rate	Boiler pressure drop (ft.)	Recommended pump option 1 Grundfos	Recommended pump option 2 Grundfos
20 °F Δt		14.6	15.8	UPS 26-99FC, 115V, Speed3	
25 °F Δt		11.7	10.0	UPS 26-99FC, 115V, Speed2	UP 26-64F, 115V
30 °F Δt		9.7	7.5	UPS 26-99FC, 115V, Speed2	
35 °F Δt		8.3	5.8	UPS 26-99FC, 115V, Speed1	
40 °F Δt		7.3	4.2	UPS 26-99FC, 115V, Speed1	
Flow limitation L/h / GPM		3500 / 15.4			

Table 7.

Model	WB2B 60	Flow rate	Boiler pressure drop (ft.)	Recommended pump option 1 Grundfos	Recommended pump option 2 Grundfos
20 °F Δt		19.4		Not Recommended	Not Recommended
25 °F Δt		15.5	16.7	UPS 26-99FC, 115V, Speed3	
30 °F Δt		12.9	12.6	UPS 26-99FC, 115V, Speed3	UP 26-64F, 115V
35 °F Δt		11.1	9.2	UPS 26-99FC, 115V, Speed2	UP 26-64F, 115V
40 °F Δt		9.7	7.5	UPS 26-99FC, 115V, Speed2	
Flow limitation L/h / GPM		3500 / 15.4			

Pump and Low-Loss Header Information

Heating Circuit / Boiler Pumps *(continued)*

Table 8.

Model	WB2B 80		
	Flow rate	Boiler pressure drop (ft.)	Recommended pump Grundfos
20 °F Δ t	26.0	16.7	UPS 32-160/2, 115V, Speed1 / UPS 26-150F, 115V, Speed 3
25 °F Δ t	20.8	9.2	UPS 26-99FC, 115V, Speed3
30 °F Δ t	17.3	6.5	UPS 26-99FC, 115V, Speed2
35 °F Δ t	14.9	4.8	UPS 26-99FC, 115V, Speed2
40 °F Δ t	13.0	3.4	UPS 26-99FC, 115V, Speed2
Flow limitation L/h / GPM	8000 / 35.2		

Table 9.

Model	WB2B 105		
	Flow rate	Boiler pressure drop (ft.)	Recommended pump Grundfos
20 °F Δ t	35.0	30.0	UPS 32-160/2, 115V, Speed3
25 °F Δ t	28.0	20.0	UPS 32-160/2, 115V, Speed2 / UPS 26-150F, 115V, Speed 3
30 °F Δ t	23.3	12.5	UPS 32-160/2, 115V, Speed1
35 °F Δ t	20.0	9.0	UPS 26-99FC, 115V, Speed3
40 °F Δ t	17.5	6.4	UPS 26-99FC, 115V, Speed2
Flow limitation L/h / GPM	8000 / 35.2		

Table 10. Sizing of Low-Loss Header in a Residential Single-Boiler Application

Boiler Model	No. of Boilers	Boiler Max. Flow Rate	Typical System Flow Rates							Viessmann Temp. Sensor Required
			System Δ t *1	20 11.0	25 13.9	30 16.8	35 16.1	40 13.4	°F °C	
WB2B 19	1	6.1 1385	System Flow Rate	6.1	4.9	4.1	3.5	3.1	GPM L/h	Yes
			LLH Required LLH Model	1385 Yes 80/60	1108 Optional 80/60	924 Optional 80/60	792 Optional 80/60	693 Optional 80/60		
WB2B 26	1	6.1 1385	System Flow Rate	8.5	6.8	5.7	4.9	4.3	GPM L/h	Yes
			LLH Required LLH Model	1931 Yes 80/60	1544 Yes 80/60	1287 Optional 80/60	1103 Optional 80/60	965 Optional 80/60		
WB2B 35	1	6.1 1385	System Flow Rate	11.4	9.1	7.6	6.5	5.7	GPM L/h	Yes
			LLH Required LLH Model	2589 Yes 80/60	2071 Yes 80/60	1726 Yes 80/60	1480 Yes 80/60	1295 Optional 80/60		
WB2B 45	1	15.4 3498	System Flow Rate	14.6	11.7	9.7	8.3	7.3	GPM L/h	Yes
			LLH Required LLH Model	3316 Yes 80/60	2653 Optional 80/60	2211 Optional 80/60	1895 Optional 80/60	1658 Optional 80/60		
WB2B 60	1	15.4 3498	System Flow Rate	19.4	15.5	12.9	11.1	9.7	GPM L/h	Yes
			LLH Required LLH Model	4406 Yes 80/60	3525 Yes 80/60	2937 Optional 80/60	2518 Optional 80/60	2203 Optional 80/60		
WB2B 80	1	35 7949	System Flow Rate	26.0	20.8	17.3	14.9	13.0	GPM L/h	Yes
			LLH Required LLH Model	5905 Yes 120/80	4724 Yes 120/80	3937 Optional 120/80	3374 Optional 120/80	2953 Optional 120/80		
WB2B 105	1	35 7949	System Flow Rate	35.2	28.0	23.3	20.0	17.5	GPM L/h	Yes
			LLH Required LLH Model	7949 Yes 120/80	6359 Yes 120/80	5300 Yes 120/80	4542 Optional 120/80	3975 Optional 120/80		

*1 For system Δt < 20°F use low-loss header sizes for Δt 20°F.

Low-Loss Header Information

Low-Loss Header Application *(continued)*

Table 11. Sizing of Low-Loss Header in a Commercial Multiple-Boiler Application

Boiler Model	No. of Boilers	Boiler Max. Flow Rate	Total Flow Rate	Typical System Flow Rates						Viessmann Temp. Sensor Required *2	
				System Δt *1	20 11.0	25 13.9	30 16.8	35 16.1	40 13.4		°F °C
WB2B 45	2	15.4 3498	30.8 6995	System Flow Rate	29.2 6632	23.4 5306	19.5 4421	16.7 3790	14.6 3316	GPM L/h	Yes
				LLH Required	Yes	Yes	Yes	Yes	Yes		
				LLH Model	120/80	120/80	120/80	120/80	120/80		
WB2B 45	3	15.4 3498	46.2 10493	System Flow Rate	43.8 9948	35.0 7958	29.2 6632	25.0 5685	21.9 4974	GPM L/h	Yes
				LLH Required	Yes	Yes	Yes	Yes	Yes		
				LLH Model	160/80	120/80	120/80	120/80	120/80		
WB2B 45	4	15.4 3498	61.6 13991	System Flow Rate	58.4 13264	46.7 10611	38.9 8843	33.4 7579	29.2 6632	GPM L/h	Yes
				LLH Required	Yes	Yes	Yes	Yes	Yes		
				LLH Model	200/120	200/120	160/80	120/80	120/80		
WB2B 60	2	15.4 3498	30.8 6995	System Flow Rate	38.8 8812	31.0 7050	25.9 5875	22.2 5036	19.4 4406	GPM L/h	Yes
				LLH Required	Yes	Yes	Yes	Yes	Yes		
				LLH Model	160/80	120/80	120/80	120/80	120/80		
WB2B 60	3	15.4 3498	46.2 10493	System Flow Rate	58.2 13219	46.6 10575	38.8 8812	33.3 7554	29.1 6609	GPM L/h	Yes
				LLH Required	Yes	Yes	Yes	Yes	Yes		
				LLH Model	200/120	200/120	160/80	120/80	120/80		
WB2B 60	4	15.4 3498	61.6 13991	System Flow Rate	77.6 17625	62.1 14100	51.7 11750	44.3 10071	38.8 8812	GPM L/h	Yes
				LLH Required	Yes	Yes	Yes	Yes	Yes		
				LLH Model	200/120	200/120	200/120	160/80	160/80		
WB2B 80	2	35 7949	70 15899	System Flow Rate	52.0 11810	41.6 9448	34.7 7874	29.7 6749	26.0 5905	GPM L/h	Yes
				LLH Required	Yes	Yes	Yes	Yes	Yes		
				LLH Model	200/120	160/80	160/80	160/80	160/80		
WB2B 80	3	35 7949	105 23848	System Flow Rate	78.0 17716	62.4 14173	52.0 11810	44.6 10123	39.0 8858	GPM L/h	Yes
				LLH Required	Yes	Yes	Yes	Yes	Yes		
				LLH Model	200/120	200/120	200/120	200/120	160/80		
WB2B 80	4	35 7949	140 31797	System Flow Rate	104.0 23621	83.2 18897	69.3 15747	59.4 13498	52.0 11810	GPM L/h	Yes
				LLH Required	Yes	Yes	Yes	Yes	Yes		
				LLH Model	250/150	250/150	200/120	200/120	200/120		
WB2B 105	2	35 7949	70 15899	System Flow Rate	70 15899	56 12719	47 10599	40 9085	35 7949	GPM L/h	Yes
				LLH Required	Yes	Yes	Yes	Yes	Yes		
				LLH Model	200/120	200/120	200/120	160/80	160/80		
WB2B 105	3	35 7949	105 23848	System Flow Rate	105 23848	84 19078	70 15899	60 13627	53 11924	GPM L/h	Yes
				LLH Required	Yes	Yes	Yes	Yes	Yes		
				LLH Model	250/150	250/150	200/120	200/120	200/120		
WB2B 105	4	35 7949	140 31797	System Flow Rate	140 31797	112 25438	93 21198	80 18170	70 15899	GPM L/h	Yes
				LLH Required	Yes	Yes	Yes	Yes	Yes		
				LLH Model	300/200	250/150	250/150	200/120	200/120		

NOTE: for multiple boiler applications when using the the Vitodens 200-W, WB2B boilers, refer to the multiple boiler low-loss distribution manifold installation instructions.

*1 For system $\Delta t < 20^\circ\text{F}$ use low-loss header sizes for $\Delta t 20^\circ\text{F}$.

*2 Low-Loss sensor - standard equipment of the Vitocontrol-S WB2B: for use in multiple boiler applications.

Domestic Hot Water Production

Vitodens 200-W boilers can be used in conjunction with the stand-alone DHW storage tanks offered by Viessmann. All Viessmann DHW storage tanks sold in North America are available in "Vitosilver" finish only.

Size and select the DHW storage tank based on the forecasted DHW consumption of the building in question. For further technical information on DHW storage tanks, see the Vitocell-V Technical Data Manuals.

For the connection of a stand-alone DHW tank, installation fittings (field supplied), an external circulating pump for DHW production (field supplied) and a DHW temperature sensor (optional equipment, see Viessmann Price List for order information) are required.

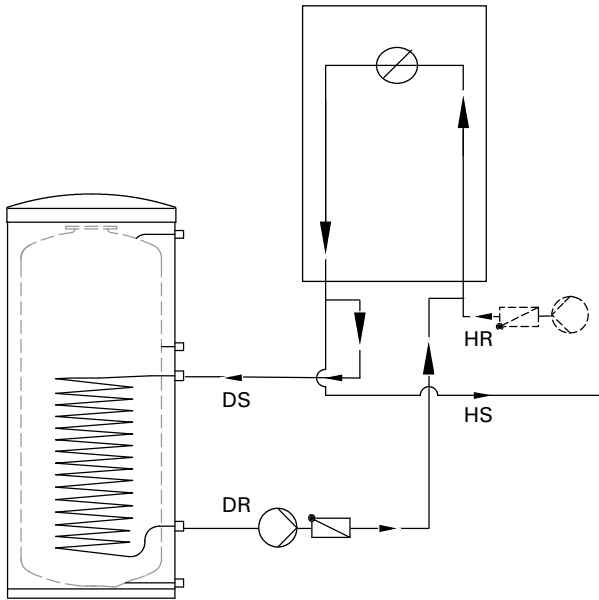

Fig. 14

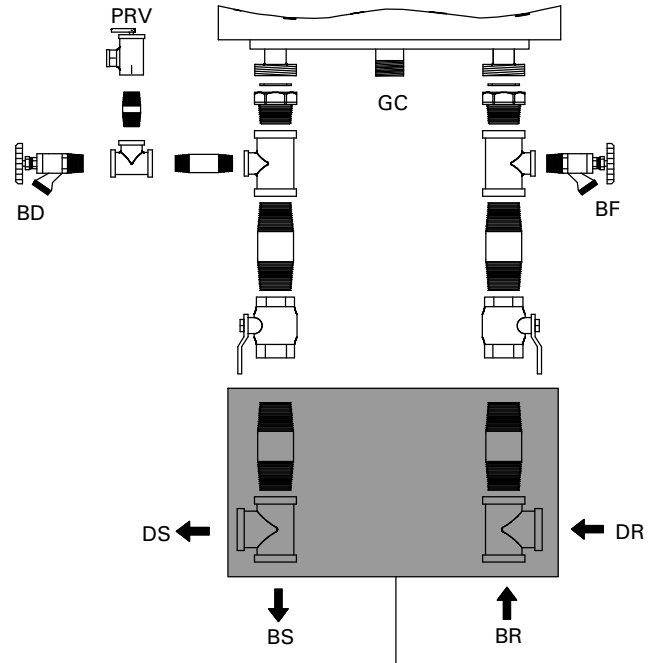

Fig. 15

Legend

- DR Boiler heating return for domestic hot water production
- DS Boiler heating supply for domestic hot water production
- HR Heating Return
- HS Heating Supply
- BD Boiler Drain
- BR Boiler Return
- BS Boiler Supply
- GC Gas Connection
- PRV Pressure Relief Valve
- BF Boiler Fill
- PG Pressure Gage (not shown)
- * 1 See page 38 for alternate DHW connection.

IMPORTANT

An adequately sized precharged expansion tank must be used. See Installation Examples for details.

DHW Recirculation

Domestic Hot Water Recirculation

DHW recirculation lines increase the level of comfort and convenience of the domestic hot water supply and reduce water consumption. These advantages directly derive from the immediate availability of domestic hot water at all draw points.

Poor insulation of the DHW recirculation line, however, can result in considerable heat loss. Viessmann therefore recommends that effective insulation be provided and used for DHW recirculation lines of **23 ft. / 7 m in length or longer**.

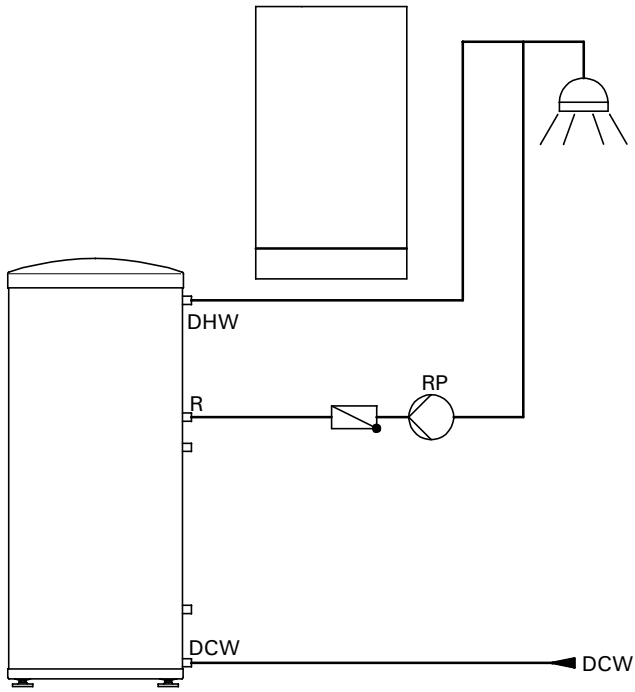

Fig. 16 Vitocell-V stand-alone DHW storage tank

Legend

- DCW Domestic Cold Water
- DHW Domestic Hot Water
- TPV Temperature and Pressure Relief Valve (on tank - not shown)
- R DHW Recirculation Line
- RP DHW Recirculation Pump

Models WB2B 19, 26, 35

The Vitodens 200-W, models WB2B 19 to 35 comes with a template, which allows you to easily mark the location of the screws for the mounting bracket and the location of the flue gas pipe on the wall.

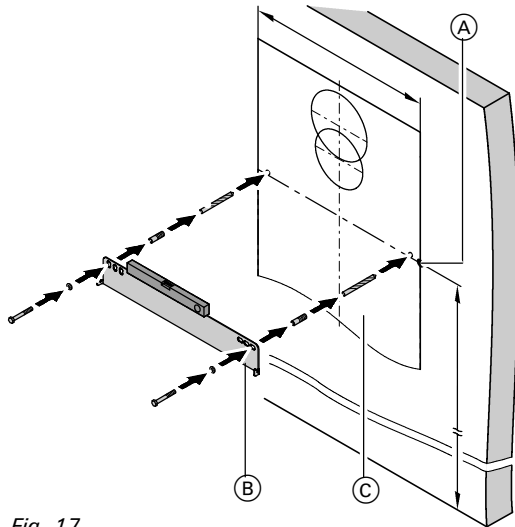
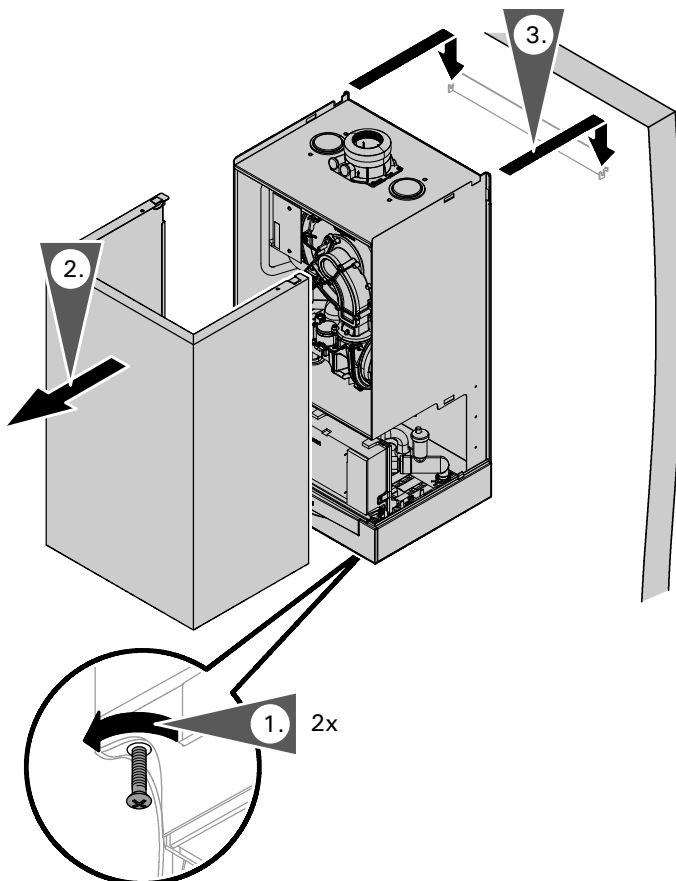

Fig. 17

Legend

- Ⓐ Reference point top edge Vitodens 200-W
- Ⓑ Mounting bracket
- Ⓒ Vitodens 200-W mounting template



1. Loosen the screws at the bottom of the boiler.
2. Remove front enclosure panel.
3. Mount boiler onto the mounting bracket and connect boiler to the installation fittings.

Fig. 18

Wall Mounting

Models WB2B 45, 60, 80, 105

The Vitodens 200-W, models WB2B 45 to 105 comes with a template, which allows you to easily mark the location of the screws for the mounting bracket and the location of the flue gas pipe on the wall.

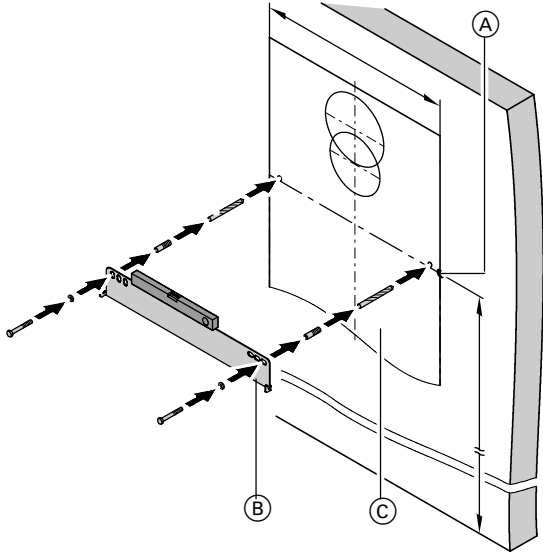

Fig. 19

Legend

- Ⓐ Reference point top edge Vitodens 200-W
- Ⓑ Mounting bracket
- Ⓒ Vitodens 200-W mounting template

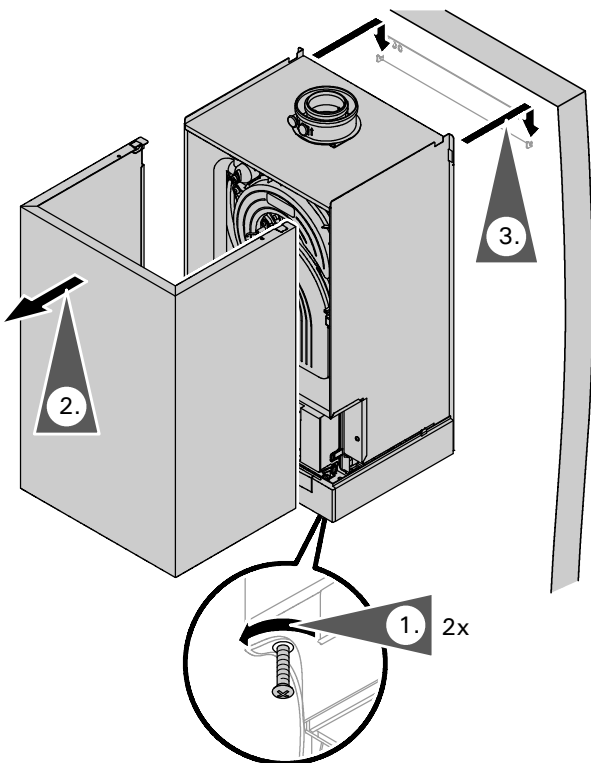

Fig. 20

1. Loosen the screws at the bottom of the boiler.
2. Remove front enclosure panel.
3. Mount boiler onto the mounting bracket and connect boiler to the installation fittings.

Condensate Connection

Install the condensate drain pipe with a suitable gradient.

Discharge condensate from the boiler into the drainage system, either directly or (if required) via a neutralization unit (accessory).

IMPORTANT

Pipe ventilation must take place between the siphon trap and the neutralization unit (if applicable).

Condensate Connection for Vitodens 200-W, models WB2B 19, 26, 35

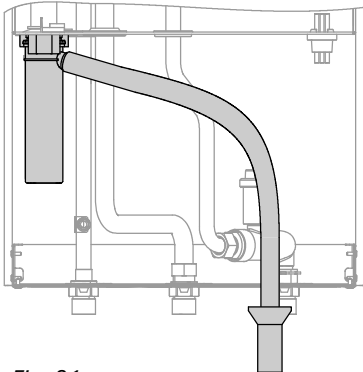

Fig. 21

Condensate Connection for Vitodens 200-W, models WB2B 45, 60

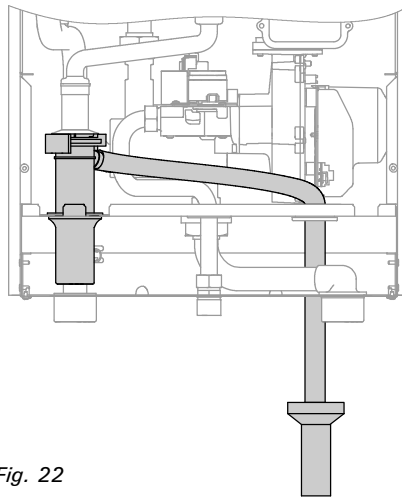

Fig. 22

Condensate Connection for Vitodens 200-W, models WB2B 80, 105

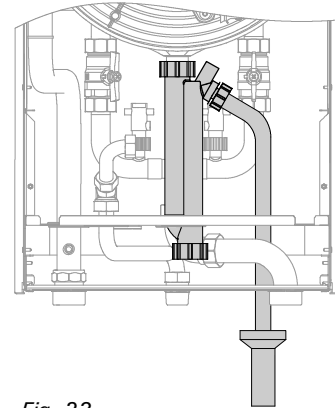

Fig. 23

Condensate Drainage and Neutralization

The condensate formed both in the condensing boiler and in the flue gas pipe must be discharged into the public sewage system in accordance with all applicable local regulations. The condensate produced by a gas-fired heating system has a pH value between 3 and 4.

Some local codes may require the use of a separate neutralization unit to treat the aggressive and corrosive nature of the condensate. With a neutralization unit installed, all condensate from the boiler and the flue gas pipe enters into the neutralization unit where it is treated and released into the public sewage system with a safe pH value of above 6.5.

The use of neutralization granulate (performing the neutralizing process) is dependent on the operation of the heating system. To determine the required refill amount, check granulate level several times during the first year of operation. In some cases one granulate fill may last an entire year.

Contact Viessmann to order a neutralization unit for the Vitodens 200-W boiler. See Viessmann Price List for order information.

The condensate discharge outlet to the drainage system connection must be clearly visible. It must be installed with a suitable gradient and provided with a stench trap.

If the condensate outlet of the Vitodens 200-W boiler is lower than the drain, a condensate pump must be used.

Only corrosion-resistant materials must be used for condensate drainage purposes (e.g. braided hose). Do not use galvanized materials or materials containing copper for piping, couplings etc. The condensate drain must have a trap to prevent flue gas leakage.

Please note that other requirements might apply depending on local regulations and/or project-specific details.

It is advisable to contact your local waterworks office (authority responsible for waste water regulations) well before commencing with the installation of the neutralization unit in order to establish details of local regulations that apply.

The following table shows the concentration of (effluent) substances (e.g. heavy metals) contained in the waste water from the Vitodens 200-W condensing boiler.

Table 12.

Condensate (effluent) substances	Values measured in mg/L Vitodens 200-W
Lead	< 0.01
Cadmium	< 0.005
Chromium	< 0.01
Copper	< 0.01
Nickel	< 0.01
Zinc	< 0.05
Tin	< 0.05

Venting Options

For an overview of venting options refer to the appendix starting on page NO TAG. For detailed information refer to the Installation Instructions for the Vitodens 200-W, WB2B Venting System.

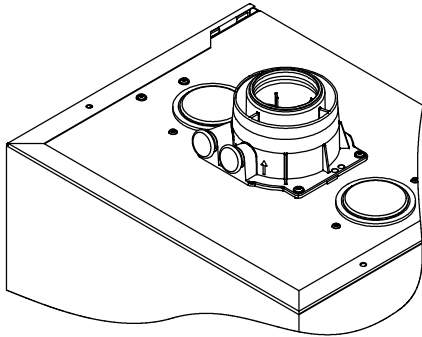

Fig. 24 Vent Connection, models WB2B 19, 26, 35 (with optional air intake openings on sides)

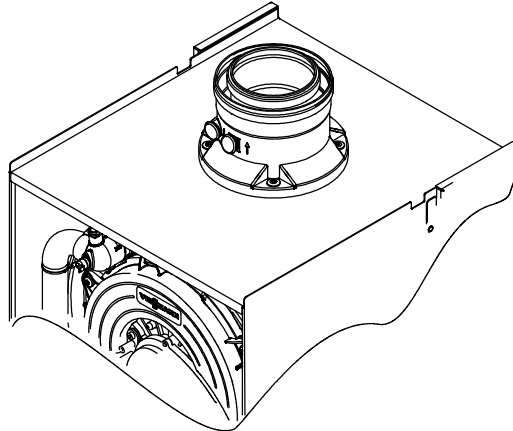

Fig. 25 Vent Connection, models WB2B 45, 60, 80, 105

Electrical Connection

For an overview of the required wiring refer to pages 39 (for WB2B 19 to 60) and 40 (for WB2B 80 and 105).

Power Supply

The Vitodens 200-W is shipped with a Power / Pump Module. The module requires a 120 VAC power supply from a wall receptacle. The module contains a 120/230 VAC step-up transformer to power the Vitodens 200-W with 230 VAC. Refer to the Installation Instructions shipped with the module for wiring details, or reference the "Overview of Electrical Connections" on pages 39 and 40 of this manual.

Power Supply Connection of Accessories

The power supply connection of accessories can be made directly at the boiler control. The connection is activated and deactivated with the system on/off switch. The mixing valve accessory kit and the Vitosolic control (if used) will require a separate 120 VAC power supply from the wall receptacle.

Wire cabling required for:

- outdoor temperature sensor
- Vitotronic 200-H, HK1M mixing valve control
- accessory kit for heating circuit with mixing valve
- Vitotrol 200 remote control
- Vitotrol 300 remote control
- remote switching of operating mode
- remote disable
- alarm output

On-Board Vitotronic 200, HO1 Outdoor Reset Control

The on-board Vitodens menu-driven Vitotronic 200, HO1 control provides the following:

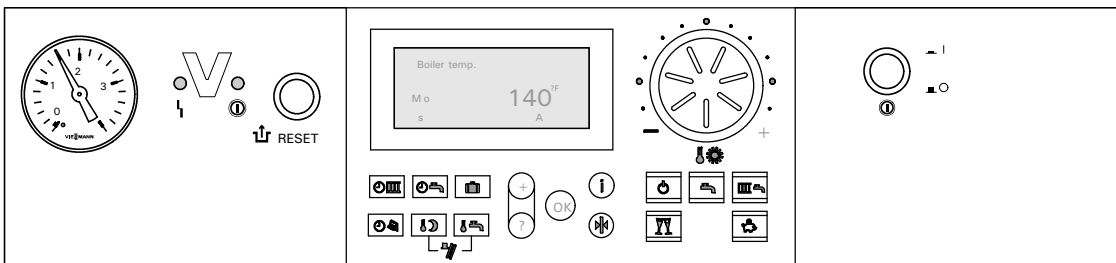

Fig. 26

Design and Functions

Modular Structure

The control unit contains:

System on/off switch, override/emission test switch, fixed high limit, adjustable high limit, digital display, micro-computer, adjustment options for switching times, for temperatures during normal and reduced operation, domestic hot water temperature, adjustment options for heating curves, temperature scanning options, built-in diagnostic system and fuses, reset button, analogue pressure display.

Programming Unit

- Illuminated display with plain text support
- Adjustment and display of temperatures and codes
- All settings, main codings and fault messages shown in plain text
- Holiday program
- Party button for switching to "normal operation" whenever required
- Energy savings button for lowering the desired room temperature by approx. 3.6°F / 2°C in normal operation
- Rotary selector for the temperature in standard mode
- Keys:
 - Program selection
 - Holiday program
 - Party and economy mode
 - Temperature for reduced mode
 - DHW temperature
 - Emissions test function
 - Time/date

Boiler-Specific Functions

The control unit adjusts the boiler water temperature (= supply temperature of a direct-connected heating circuit and/or a heating circuit with mixing valve in conjunction with the accessory kit for a heating circuit with mixing valve) automatically and on a continuous basis to individual outdoor temperatures. The control has a DHW temperature controller with DHW priority switching (heating circuit pump off).

Functions

- Outdoor reset control of boiler water and/or supply temperature
- Electronic maximum temperature limit
- Demand-dependent heating circuit pump and burner OFF control
- Anti-seizing pump protection
- Maintenance display
- Heating system frost protection
- Integral diagnostic system
- DHW temperature control with priority control

- Auxiliary function for DHW heating (short-term heating to a higher temperature, gas fired central heating boiler)
- Adjusting switching times for the DHW recirculation pump
- 0-10 V external signal input
- Boiler pump control output
- Alarm output
- Heating circuit pump control output
- DHW pump control output
- DHW recirculation pump control output

Control Characteristics

PI characteristics with modulating output.

Time Switch

Digital time switch.

- Individual and 7-day program
 - Automatic daylight savings time changeover
 - Automatic function for DHW heating and DHW recirculation pump
 - Time, day and standard switching times for space heating, DHW heating and the DHW circulation pump are factory-set
 - Switching times are individually programmable, i.e. up to four switching periods per day
- Shortest switching interval: 10 minutes
Power backup: 14 days.

Setting the Heating Programs

The heating system frost protection (see frost protection function) applies to all heating programs.

You can select the following heating programs with the program keys:

- Heating and DHW
 - DHW only
 - Standby mode
- External heating program changeover.

Summer Operation

Heating program "☀"

The burner is only activated upon a call for domestic hot water from the DHW storage tank (controlled by DHW tank temperature sensor).

Frost protection

- The frost protection function will be started when the outside temperature drops below approx. 34°F / +1°C. With the frost protection function, the heating circuit pump will be switched ON and the boiler water is maintained at a lower temperature of approx. 68°F / 20°C. The DHW tank will be heated to approx. 68°F / +20°C.
- The frost protection function will be stopped when the outside temperature rises above approx. 37°F / +3°C (default settings).

Technical Data

Rated supply voltage:	120 VAC
Rated frequency:	60 Hz
Rated current:	12 A
Max. ambient temperature	
■ at operation:	32 to 104°F 0 to 40°C
	Installation in living spaces or boiler rooms (standard ambient conditions)
■ when storing or transporting:	-4 to +158°F -20 to +70°C

Max. operating temp. setting (space heating):

Models WB2B 19-60	165°F / 74°C
Models WB2B 80-105	176°F / 80°C

DHW production:

Models WB2B 19-60	165°F / 74°C
Models WB2B 80-105	176°F / 80°C

Setting fixed

high limit:	210°F / 99°C (not adjustable)
-------------	----------------------------------

Adjustment range of DHW tank set-point temperature:

50 to 154°F 10 to 68°C

Adjustment range heating curves

- Heating curve slope 0.2 to 3.5
- Heating curve shift: -12 to +33°C
-13 to 40 K

Boiler Control

Heating Curve Adjustment (slope and shift)

The control unit regulates the boiler water temperature (= supply temperature of heating circuit without mixing valve) and the supply temperature of the heating circuit with mixing valve (in conjunction with the accessory kit for a heating circuit with mixing valve) according to the outdoor temperature. The boiler water temperature is automatically raised by 0 to 72 F / 0 to 40 K higher than the currently required set supply temperature (in the factory default setting the differential temperature is 14.4 F / 8 K). See Start-up/Service Instructions for coding address "9F" in coding level 2.

The supply temperature that is required to achieve a given room temperature depends on the heating system and the thermal insulation of the building that is being heated.

The adjustment of the two heating curves is used to match the boiler water temperature and the supply temperature to these conditions. The boiler water temperature is limited upwards by the fixed high limit and the temperature set for the electronic high limit.

The supply temperature cannot rise above the boiler water temperature.

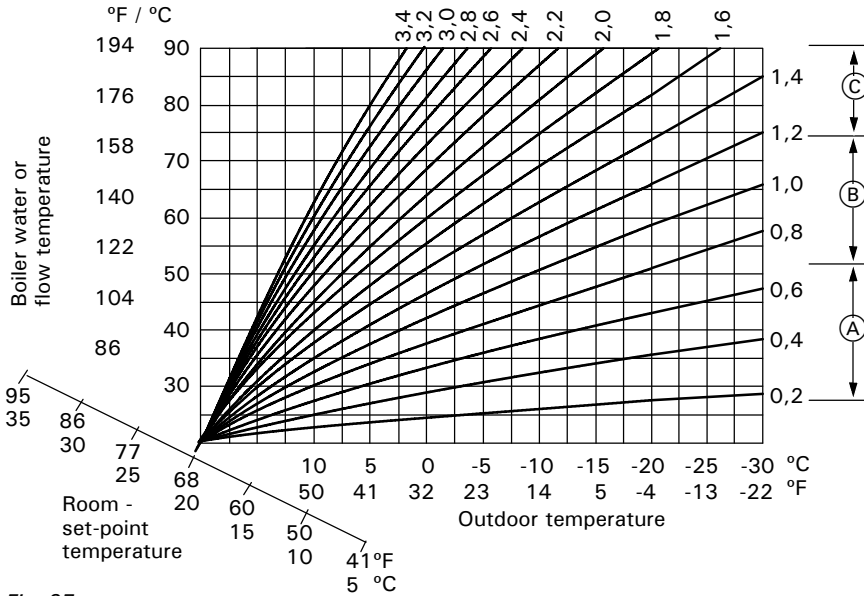

Fig. 27

Legend

- (A) Low temperature heating system, e.g. radiant floor heating
- (B) Medium temperature heating system, e.g. cast iron radiation, staple-up radiant floor heating
- (C) High temperature heating system, e.g. fintube radiation, fan coils

Boiler Temperature Sensor

The boiler temperature sensor is connected at the control unit for weather-responsive operation and is built into the boiler.

Max. ambient temperature

- at operation: 32 to 266°F / 0 to 130°C
- when storing or transporting: -4 to +158°F / -20 to +70°C

DHW Tank Temperature Sensor

Part No. 7179 114

Supplied with:

- Cable length approx. 13 ft. / 3.75 m, ready to plug in
- All pipe connections are field supplied.

Specification

Max. ambient temperature

- at operation: 32 to 194°F / 0 to 90°C
- when storing or transporting: -4 to +158°F / -20 to +70°C

Outdoor Temperature Sensor

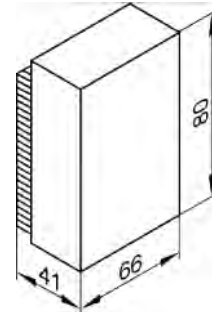

Fig. 28 (dimensions in mm)

Sensor location:

- North or northwest wall of building
- 6.6 to 8.2 ft. / 2 to 2.5 m above ground or in case of a multi-storey building approx. halfway up the second floor

Electrical connection:

- 2-wire cable, max. cable length 115 ft. / 35 m with a wire size of min. AWG 16 copper
- Cable to the outdoor sensor must not be laid near line voltage wiring (120/240 V)

Max. ambient temperature at

- operation, when storing or transporting: -40 to +158°F / -40 to +70°C

Vitotronic Control Accessories

Mixing Valve Actuator Accessory Kit,
Part No. 7133 392 (old version)

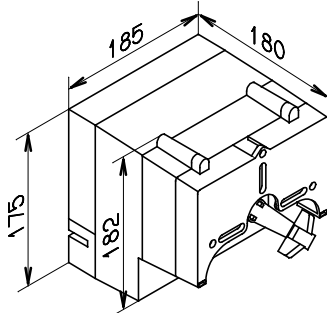

Fig. 29 (dimensions in mm)

Rated voltage: 120 VAC
 Rated frequency: 60 Hz
 Rated current: 4 (2) A
 Power consumption: 4 W
 Max. ambient temperature
 ■ at operation: 32 to 104°F
 0 to 40°C
 ■ when storing
 or transporting: -4 to +149°F
 -20 to +65°C
 Relay output for
 heating circuit pump: 4(2) A, 120 VAC
 Actuator torque: 3 Nm
 Time of 90 °±: 2 minutes

Supply Temperature Sensor

(strap-on sensor, included with mixing
 valve actuator accessory kit),
 Part No. 7133 895 (old version)
 ■ when storing or transporting:
 -20 to +70°C

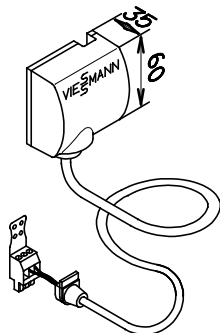

Fig. 30 (dimensions in mm)

Installed with a strapping band.
 Cable length 19.7 ft. / 6 m, ready to plug
 in. Max. ambient temperature
 ■ at operation: 32 to 212°F
 0 to 100°C
 ■ when storing or transporting:
 -4 to +149°F (-20 to +70°C)

Mixing Valve Actuator Accessory Kit,
Part No. 7837 524 (new version)

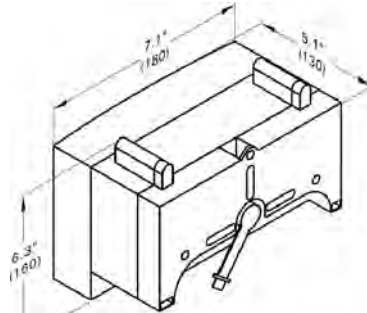

Fig. 31 (mm)

The mixing valve actuator is mounted directly
 on the Viessmann ¾ to 2½" mixing valve.
 The mixing valve actuator is a motor-driven
 control unit. The rotational direction is
 reversible.
 The mixing valve actuator comes with a
 plug-in connector for a heating circuit pump,
 supply temperature sensor (strap-on sensor
 with 7 ft. / 2.1 m connecting cable), power
 supply connecting cable (9 ft. / 2.7 m) and a
 connecting cable (9 ft. / 2.7 m) for the
 KM-BUS Expansion Module.

Rated voltage: 120 VAC
 Rated frequency: 60 Hz
 Rated current: 4 A

Power consumption: 5W max. ambient
 temperature
 - at operation: 32°F to 104°F (0°C to 40°C)
 application in living areas and installation
 sites (normal ambient conditions)
 -storage & shipping: -4°F to 149°F (-20°C
 to 65°C)
 Max. relay outputs at 120 VAC for:
 - Heating circuit pump 1.0 A
 - Mixing valve 0.2 A

Supply Temperature Sensor
 Part No. 7183 288 (new version)

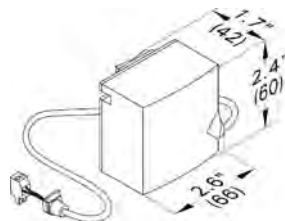

Fig. 32 (mm)

LON Communication Module

Part No. 7179 113
 Electronic PCB for data exchange with the
 Vitotronic 200-H, Vitocom 200 and for
 connecting to a higher level building
 management system.

LON Connecting Cable
 (for data exchange between control units)
 Cable length 23 ft / 7m, fully wired

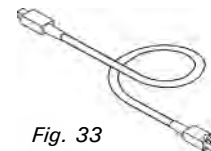

Fig. 33

LON Terminal End Resistor

Part No. 7143 497
 To terminate the LON BUS at the first and
 the last control unit.

KM BUS Expansion Module

Part No. 7133 393
 To connect 2 to 9 devices (mixing valve
 actuator, Vitotrol, input module, etc.) to the
 single KM BUS connection of the boiler.

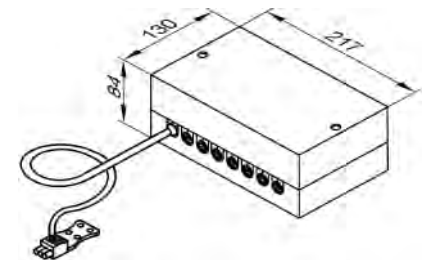

Fig. 34 (dimensions in mm)

Specification

Lead length 10 ft / 3.0 m,
 fully wired
 Permissible ambient temperature
 - during operation 32 to 104°F
 0 to 40°C
 - during storage and
 transport - 4 to +149°F
 -20 to +65°C

Immersion temperature sensor

Part No. 7173 488
 To capture the low loss temperature

Specification

Lead length 12 ft / 3.75 m,
 fully wired
 Permissible ambient temperature
 - during operation 32 to 194°F
 0 to 90°C
 - during storage and
 transport - 4 to +158°F
 -20 to +70°C

Vitotrol 200
Part No. 7450 017

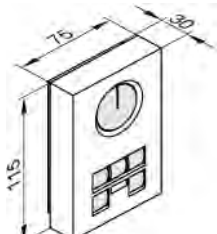

Fig. 35 (dimensions in mm)

KM BUS subscriber

The Vitotrol 200 remote control regulates the heating program for one heating circuit and the required set room temperature in standard mode, from any room in the house.

The Vitotrol 200 is equipped with backlit heating program selection keys as well as a party and economy key.

The fault display shows faults on the control unit.

WS function:

Installation anywhere in the building.

RS function:

Installation in the main living room on an internal wall opposite radiators. Never install inside shelf units, recesses, immediately by a door or heat source (e.g. direct sunlight, fireplace, TV set, etc.).

The integral room temperature sensor captures the actual room temperature and effects any necessary corrections of the supply temperature as well as a rapid heat-up at the start of the heating operation (if appropriately programmed).

Connection:

- 2-core lead, length max. 164 ft / 50 m (even if connecting several remote control units)
- Never route this lead immediately next to 230/400 V cables
- LV plug part of the standard delivery

Specification

Power supply via KM BUS

Power consumption 0.2 W

Protection class III

Max. ambient temperature

- at operation: 32 to 104°F
0 to 40°C

- when storing or transporting: -4 to +149°F
-20 to +65 °C

Set room temp. range 50 to 86°F
10 to 30°C
adjustable from 37 to 74°F
3 to 23°C or 63 to 99°F
17 to 37°C

The set room temperature for reduced mode is adjusted at the control unit.

Vitotrol 300
Part No. 7248 907

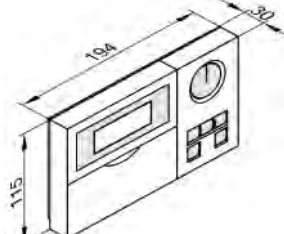

Fig. 36 (dimensions in mm)

KM BUS subscriber

The Vitotrol 300 remote control regulates the required set room temperature for one heating circuit in standard and reduced mode, the heating program and the switching times for central heating, DHW heating and the DHW circulation pump.

The Vitotrol 300 provides a backlit display as well as backlit heating program keys, a party and economy key, automatic summer/winter time changeover, keys for holiday program, day and time.

WS function:

Installation at any point in the building.

RS function:

Installation in the main living room on an internal wall opposite radiators. Never install inside shelf units, niches, immediately by a door or heat source (e.g. direct sunlight, fireplace, TV set, etc.).

The integral room temperature sensor captures the actual room temperature and affects any necessary correction of the supply temperature as well as a rapid heat-up at the start of the heating operation (if suitable encoded).

Connection:

- 2-core lead, length max. 164 ft / 50 m (even if connecting several remote control units)
- Never route this lead immediately next to 230/400 V cables
- LV plug part of the standard delivery

Specification

Power supply via KM BUS

Power consumption 0.5 W

Protection class III

Max. ambient temperature

- at operation: 32 to 104°F
0 to 40°C

- when storing or transporting: -4 to +149°F
-20 to +65°C

Set room temp. range for standard mode 50 to 86°F
10 to 30°C
adjustable from 37 to 74°F
3 to 23°C or 63 to 99°F
17 to 37°C
for reduced mode 37 to 99°F
3 to 37°C

Room Temperature Sensor,
Part No. 7133 379

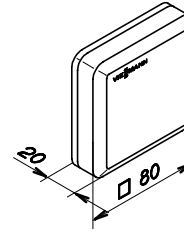

Fig. 37 (dimensions in mm)

Separate room temperature sensor as supplement to the Vitotrol 200 and 300; to be used if the the Vitotrol 200 or 300 cannot be installed inside the main living room or in a suitable position where the unit can capture and adjust the temperature. Installation in the main living room on an internal wall opposite radiators. Never install inside shelf units, recesses, immediately by a door or heat source (e.g. direct sunlight, fireplace, TV set, etc.).

Connect the room temperature sensor to the Vitotrol 200 or 300.

Electrical connection:

- 2-wire cable with a wire size of min. AWG 18 copper
 - The cable length between the control unit, remote control unit and room temperature sensor must not exceed 98 ft./30 m
- Max. ambient temperature
- at operation: 32 to 104°F
0 to 40°C
 - when storing or transporting: -4 to +149°F
-20 to +65°C

Accessories for Vitodens 200-W

Neutralization Unit for Single-Boiler Applications

with neutralizing granulate

for models WB2B 19, 26, 35
Part No. 7134 231

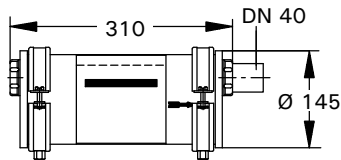

Fig. 38 (dimensions in mm)

for models WB2B 45, 60
Part No. 7134 232

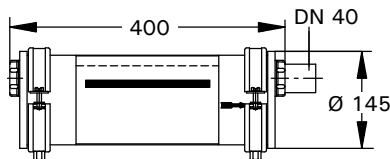

Fig. 39 (dimensions in mm)

for models WB2B 80, 105
Part No. 7264 769

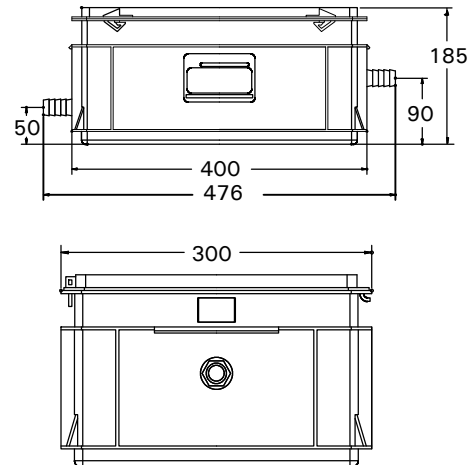

Fig. 40 (dimensions in mm)

Neutralization Pellets

for models WB2B 19, 26, 35, 45, 60

Part No. 9524 670

2 x 1.3 kg for refill or replacement purposes

for models WB2B 80, 105

Part No. 9521 702

8 kg for refill or replacement purposes

Fuel Conversion Label Kit (NG > LPG)

Part No. 7428 427

(included in boiler technical literature set)
The Vitodens 200-W, WB2B boiler comes

factory set for operation with natural gas. All WB2B models can be field converted to operate with liquid propane gas (as well as back to natural gas as required). The kit includes instructions and labels for field conversion.

Low-Loss Header

-Type 80/50

Part No. 7134 230

(max. flow rate 17.6 GPM / 4 m³/h)

-Type 120/80

Part No. 7134 244

(max. flow rate 35.2 GPM / 8 m³/h)

-Type 160/80

Part No. 7134 293 *1

(max. flow rate 44 GPM / 10 m³/h)

-Type 200/120

Part No. 7134 294 *1

(max. flow rate 80 GPM / 18 m³/h)

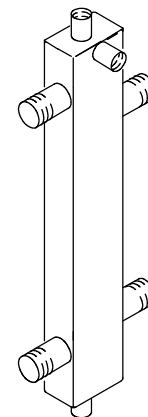

Fig. 41

When used in conjunction with the Vitodens 200-W boiler, the low-loss header acts as hydraulic break, decoupling boiler and system circuits from each other.

It is recommended to use the low-loss header in applications in which the total system flow rate exceeds the maximum (or minimum) boiler flow rate.

For maximum boiler flow rates, see pages 10 and 11 in this manual.

Viessmann strongly recommends the use of a low-loss header in cases where the system head and flow rates are unknown.

*1 Floor-mounted version (typically used for multiple-boiler installations).

Boiler Accessories

Accessories for Vitodens 200-W (continued)

Low-Loss Header (continued)

The temperature sensor connection [TS] typically located at the top of the low-loss header ensures low return temperatures to the Vitodens 200-W boiler at all times, increasing operational efficiency. In addition, the low-loss header helps eliminate air and debris [D] from the heating system. See figures on the right for an illustration of the principle of operation.

The low-loss header is available in the following sizes. Select the size based on the maximum system flow rate of your application.

Table 13.

Model No.	Max. system flow rate
Type 80/50	17.6 GPM / 4 m ³ /h
Type 120/80	35.2 GPM / 8 m ³ /h
Type 160/80* [†]	44 GPM / 10 m ³ /h
Type 200/120* [†]	80 GPM / 18 m ³ /h

*[†]Floor-mounted version (typically used for multiple-boiler installations).

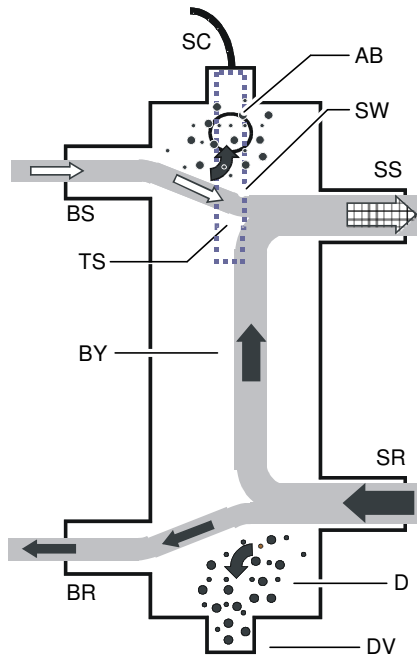

Fig. 42 Low-loss header design (Type 80/50 or 120/80)

Legend

- AB Air Bleed
- BR Boiler Return
- BS Boiler Supply
- BY Bypass (with laminar flow)
- D Debris and/or air
- DV Drain Valve
- SC Sensor Cable
- SR System Return
- SS System Supply
- TS Viessmann Temperature Sensor
- SW Sensor Well

IMPORTANT

Use only a Viessmann supplied temperature sensor. Do not use any other manufacturer's temperature sensor.

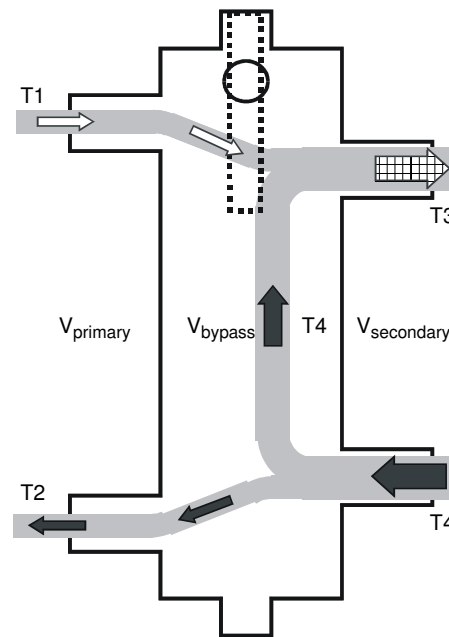

Fig. 43 Principle of Operation

Legend

- T1 Boiler supply temperature
- T2 Boiler return temperature
- T3 System supply temperature
- T4 System return temperature
- V_{primary} Boiler circuit flow rate
- V_{secondary} Heating circuit flow rate
- V_{bypass} Bypass flow rate
- Q_{primary} Heat supplied by boiler
- Q_{secondary} Heat consumed by system

$$V_{\text{primary}} < V_{\text{secondary}}$$

$$T1 > T3$$

$$T2 = T4$$

$$Q_{\text{primary}} = Q_{\text{secondary}}$$

$$T1 \leq 167^{\circ}\text{F} / 75^{\circ}\text{C}$$

$$V_{\text{secondary}} = V_{\text{primary}} + V_{\text{bypass}}$$

IMPORTANT

When installing a low-loss header, the system mixed supply temperature (T3) must be calculated as follows:

$$T3 = \frac{T1 \times V_{\text{primary}} + T4 \times V_{\text{bypass}}}{V_{\text{secondary}}}$$

Standard Equipment

The Vitodens 200-W gas-fired condensing boiler with Inox-Radial heat exchanger, modulating MatriX cylinder burner for liquid propane gas and natural gas (available on all models), comes standard with:

- pressure gage
- installation fittings with 30 psig pressure relief valve and air vent (no air vent for models WB2B 80 and 105)
- boiler control unit with outdoor temperature sensor, power/pump module

- The boiler comes prewired and fully piped internally for field connections and prewired.
- **Venting material (coaxial) is to be supplied by Viessmann only. Side wall vent installations must include Viessmann protective screen!**
- Enclosure finish:
black steel, powder-coated white
- The Vitodens 200-W comes ready for use with natural gas and can be fuel converted to liquid propane gas in the field.
- Power/Pump module

Wall mounting componentry

The following wall mounting components are supplied with the Vitodens 200-W boiler:

- Mounting bracket
- Mounting bolts
- Installation fittings
- Screws for mounting bracket on
 - wood studs (2" x 4")
 - metal studs
 - brick/concrete wall

Lambda Pro Combustion Management System

The combustion management system utilizes the physical correlation between the level of the ionization current and the air factor λ . For all gas qualities, the maximum ionization current results with air factor 1. The ionization signal is evaluated by the combustion management system, and the air factor is adjusted to between $\lambda = 1.24$ and 1.44. This range provides for an optimum combustion quality. Thereafter, the electronic gas valve regulates the required gas volume based on the prevailing gas quality.

To check the combustion quality, the CO₂ content or the O₂ content of the flue gas is measured. The actual values enable the prevailing air factor to be determined. The relationship between the CO₂ or O₂ content and air factor λ is illustrated in the table below.

To achieve an optimum combustion control, the system regularly performs an automatic self-calibration; also after a power failure (shutdown). For this, the combustion is briefly regulated to max. ionization current (equals air factor $\lambda = 1$). The automatic calibration is performed shortly after the burner starts and lasts approx. 5 s. During the calibration, higher than normal CO emissions may occur briefly.

The combustion management system can also be calibrated manually, e.g. after maintenance or service work (coding address "85", see Start-up/Service Instructions).

Table 14. Air factor λ - CO₂/O₂ content

Air factor λ	O ₂ content (%)	CO ₂ content (%) for natural gas	CO ₂ content (%) for liquid propane gas
1.24	4.4	9.2	10.9
1.27	4.9	9.0	10.6
1.30	5.3	8.7	10.3
1.34	5.7	8.5	10.0
1.37	6.1	8.3	9.8
1.40	6.5	8.1	9.6
1.44	6.9	7.8	9.3

The Vitodens 200-W, WB2B boilers come equipped with Lambda Pro, the industry's first intelligent combustion management system. The boiler adjusts automatically to any gas type and quality without the need for a fuel conversion kit.

Installation Examples

Installation Examples

→ Please note that in the following piping layout examples all pumps are field supplied.

IMPORTANT

The examples on the following pages depict possible piping layouts of the Vitodens 200-W boiler equipped with Viessmann System Technology.

For boiler and tank combinations, please install only feasible combinations listed in the Viessmann Price List.

Please note that the following examples are simplified conceptual drawings only!

Piping and necessary componentry must be field verified.

A low water cut-off (LWCO) must be installed where required by local codes.

Proper installation and functionality in the field is the responsibility of the heating contractor.



WARNING

If a DHW storage tank other than a Viessmann Vitocell 100 or 300 tank is used, the installer must verify proper operation of the Viessmann DHW tank temperature sensor with the original manufacturer of the tank. Viessmann strongly recommends the installation of a temperature tempering valve in the DHW supply line.

IMPORTANT

DHW supply and return piping between boiler DHW connections and the Viessmann DHW tank connections, shall be a minimum of 1" nominal pipe diameter (for models WB2B 19 to 35) or 1 ¼" (for models WB2B 45 to 105) DHW connection outlet sizes provided on the boiler and the DHW tank). This will ensure the residual head of the field supplied pump is fully utilized to overcome the resistance of the DHW heat exchanger coil and to provide sufficient water flow to the boiler heat exchanger. In non-Viessmann DHW tank applications, perform, in addition to the above, accurate calculations for DHW tank coil pressure drop versus boiler pump (field supplied) residual head to ensure sufficient water flow to the boiler heat exchanger. Failure to heed the above instructions may cause boiler short-cycling and inadequate DHW supply.

System Layout 1

Vitodens 200-W, WB2B with a direct-connected heating circuit

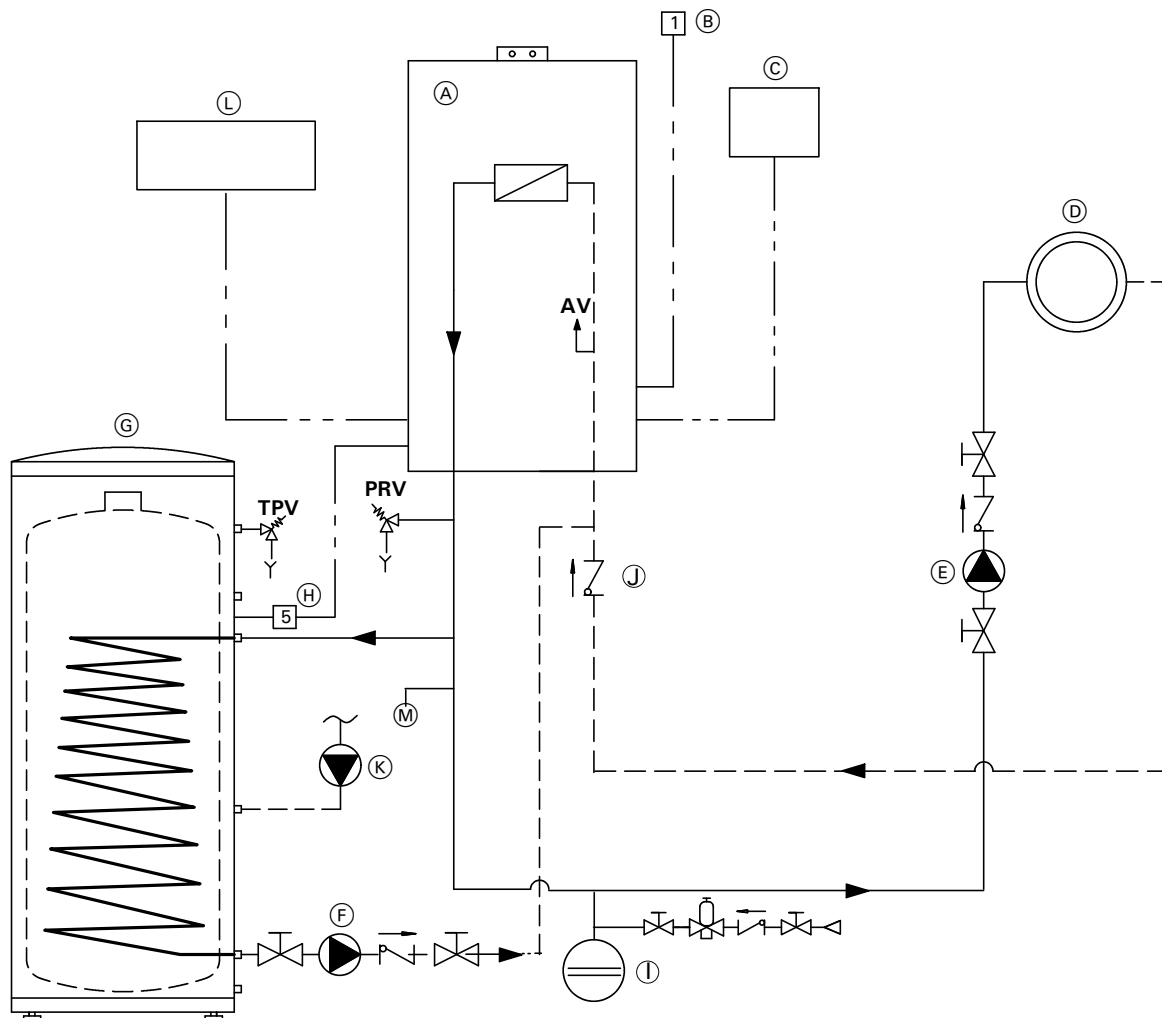

Fig. 44

Legend

- AV** Air vent (models WB2B 19 to 60 only)
- PRV** Pressure relief valve
- TPV** Temperature and pressure relief valve
- (A) Vitodens 200-W WB2B boiler with Vitotronic 200, HO1 outdoor reset control
- (B) Outdoor temperature sensor [1]
- (C) Remote control Vitotrol 300 (optional)
- (D) Heating circuit
- (E) Heating circuit pump [20]
- (F) DHW circulating pump [21]
- (G) DHW storage tank
- (H) DHW tank temperature sensor [5]
- (I) Expansion tank
- (J) Flow check valve
- (K) DHW recirculation pump [28]
- (L) Power/Pump module
- (M) Optional purge tee (field supplied)

Installation of ...

- radiator heating circuit (high-temp. circuit)
- DHW production

... with the following flow conditions:

The flow rate of the heating circuit is **less** than the maximum possible water flow rate of the Vitodens 200-W WB2B boiler (see page 10 for maximum water flow rate of boiler).

The use of a low-loss header is strongly recommended if the maximum water flow rate in the application concerned exceeds the values shown in the applicable table on page 11, or if the system flow rates are unknown.

The low-loss header is available as accessory part.

See following pages for installation examples with a low-loss header.

IMPORTANT

DHW circulating pump (F) must pump into the Vitodens 200-W boiler (as illustrated).

System Layout 2

Vitodens 200-W, WB2B with a direct-connected heating circuit and low-loss header

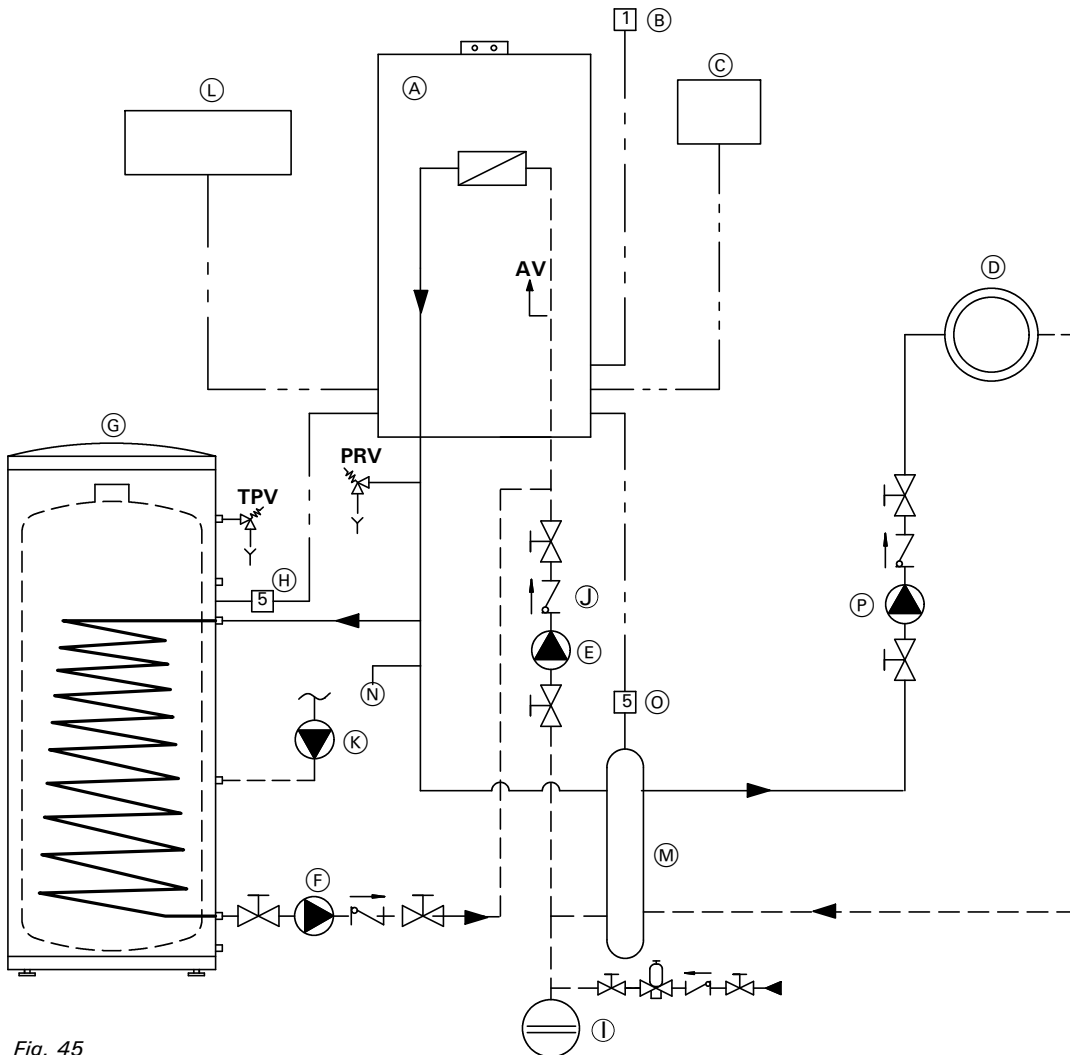

Fig. 45

Legend

- AV** Air vent (models WB2B 19 to 60 only)
- PRV** Pressure relief valve
- TPV** Temperature and pressure relief valve
- (A)** Vitodens 200-W WB2B boiler with Vitotronic 200, HO1 outdoor reset control
- (B)** Outdoor temperature sensor [1]
- (C)** Remote control Vitotrol 300 (optional)
- (D)** Heating circuit
- (E)** Boiler pump [20]
- (F)** DHW circulating pump [21]
- (G)** DHW storage tank
- (H)** DHW tank temperature sensor [5]
- (I)** Expansion tank
- (J)** Flow check valve
- (K)** DHW recirculation pump [28]
- (L)** Power/Pump Module
- (M)** Low-loss header
- (N)** Optional purge tee (field supplied)
- (O)** Viessmann temperature sensor for low-loss header [5]

- (P)** Heating circuit pump [20A]

Installation of ...

- radiator heating circuit (high-temp. circuit)
- DHW production

... with the following flow conditions:

The flow rate of the heating circuit is **greater** than the maximum possible water flow rate of the Vitodens 200-W WB2B boiler (see page 10 for maximum water flow rate of boiler).

The use of a low-loss header is strongly recommended if the maximum water flow rate in the application concerned exceeds the values shown on page 11, or if the system flow rates are unknown.

The low-loss header is available as accessory part.

IMPORTANT

Please note location of expansion tank (I) and flow check valve (J) .

IMPORTANT

DHW circulating pump (F) must pump *into* the Vitodens 200-W WB2B boiler (as illustrated).

IMPORTANT

DHW circulating pump (F) must pump *into* the Vitodens 200 boiler (as illustrated).

System Layout 3

Vitodens 200-W, WB2B with...

- DHW storage tank
- one heating circuit with mixing valve and system separation

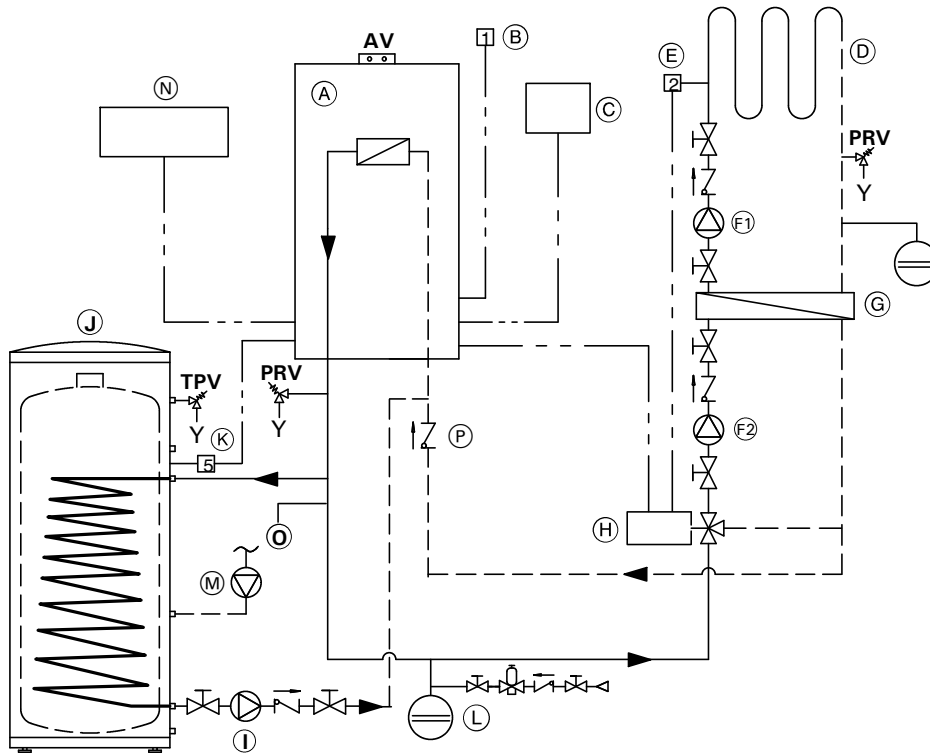

Fig. 46

Legend

- AV** Air vent (WB2B models 19 to 60 only)
- PRV** Pressure relief valve
- TPV** Temperature and pressure relief valve
- (A)** Vitodens 200-W WB2B boiler with Vitotronic 200, HO1 outdoor reset control
- (B)** Outdoor temperature $\bar{1}$
- (C)** Remote control Vitotrol 300 (optional)
- (D)** Underfloor heating circuit
- (E)** Mixing valve temperature sensor $\bar{2}$
- (F1)** Heating circuit pump
- (F2)** Heating circuit pump located upstream of heat exchanger (see IMPORTANT note to the right)
- (G)** Plate heat exchanger for system separation
- (H)** Accessory kit for heating circuit with mixing valve
- (I)** DHW circulating pump $\bar{21}$
- (J)** DHW storage tank
- (K)** DHW tank temperature sensor $\bar{5}$
- (L)** Expansion tank
- (M)** DHW recirculation pump $\bar{28}$
- (N)** Power/Pump module
- (O)** Optional purge tee (field supplied)
- (P)** Flow check valve

Installation of ...

- underfloor heating circuit with 3-way mixing valve and system separation (low-temp. circuit)
 - DHW production
- ... with the following flow conditions:**
 The flow rate of the heating circuit is **less** than the maximum possible water flow rate of the Vitodens 200-W WB2B boiler. See page 10 for maximum water flow rate of the Vitodens 200-W WB2B boilers. The use of a low-loss header is recommended if the system water flow rate is unknown. The low-loss header is available as accessory part.

See following pages for installation examples with a low-loss header.

IMPORTANT

System separation is required of underfloor heating systems employing non-oxygen diffusion barrier tubing. All components on the secondary side of the heat exchanger must be made of corrosion-resistant materials.

IMPORTANT

DHW circulating pump (I) must pump into the Vitodens 200-W WB2B boiler (as illustrated).

IMPORTANT

Sizing of field-supplied pump (F2) is critical for proper boiler operation in this system layout. See page 10 for the supply head pressure drop of the boiler. An undersized pump may cause short-cycling and/or improper operation of the boiler. Viessmann STRONGLY recommends using a low-loss header and a boiler pump in this system layout.

Installation Examples

System Layout 4

Vitodens 200-W, WB2B with...

- DHW storage tank
- one direct-connected heating circuit
- one heating circuit with a mixing valve

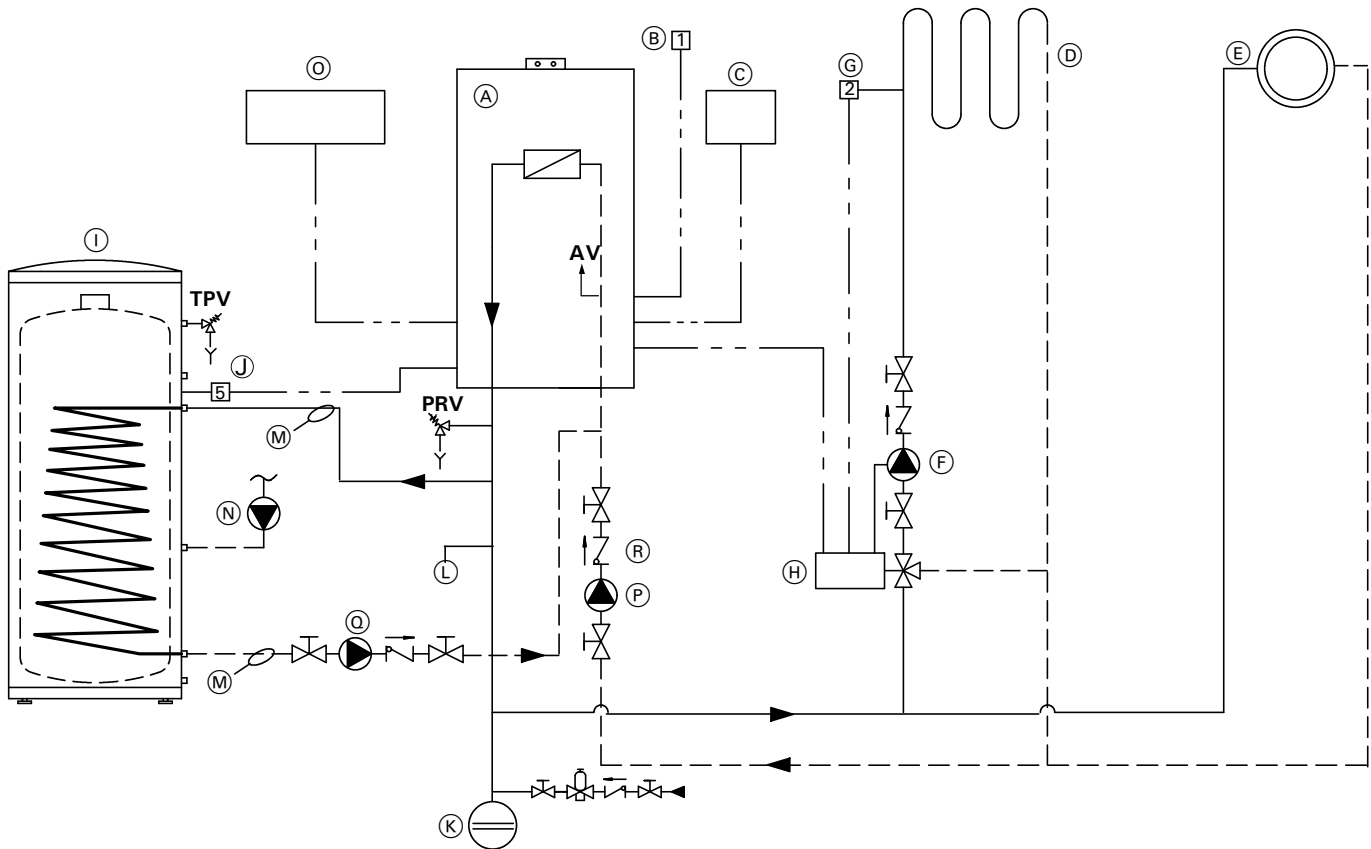

Fig. 47

Legend

- AV** Air vent (WB2B models 19 to 60 only)
- PRV** Pressure relief valve
- TPV** Temperature and pressure relief valve
- (A) Vitodens 200-W WB2B boiler with Vitotronic 200, HO1 outdoor reset control
- (B) Outdoor temperature sensor [1]
- (C) Remote control Vitotrol 300 (optional)
- (D) Under floor heating circuit
- (E) Radiator heating circuit
- (F) Heating circuit pump
- (G) Mixing valve temperature sensor [2]
- (H) Accessory kit for heating circuit with mixing valve
- (I) Domestic hot water storage tank
- (J) DHW tank temperature sensor [5]
- (K) Expansion tank
- (L) Optional purge tee (field supplied)
- (M) DHW supply and return piping
- (N) DHW recirculation pump [28]
- (O) Power/Pump module
- (P) Boiler pump [20]
- (Q) DHW circulating pump [21]
- (R) Flow check valve

Installation of different heating circuits...

- radiator heating circuit (high-temp. circuit)
 - under floor heating circuit with 3-way mixing valve (low-temp. circuit)
 - DHW production
- ... with the following flow conditions:
1. The water flow rate (output) of the radiator heating circuit is at least 30% greater than that of the under floor heating circuit.
 2. The total flow rate of the two heating circuits is **less** than the maximum possible water flow rate of the Vitodens 200-W WB2B boiler (see page 10 for max. water flow rate).
- The use of a low-loss header is strongly recommended if the maximum water flow rate in the application concerned exceeds the values shown on page 11, or if the system flow rates are unknown. The low-loss header is available as accessory part.

See following pages for additional installation examples with a low-loss header.

The 3-way mixing valve, built-in to achieve the low-temperature level of the under floor heating circuit, is controlled by an accessory kit for a heating circuit with mixing valve.

IMPORTANT

DHW circulating pump (Q) must pump *into* the Vitodens 200-W WB2B boiler (as illustrated).

System Layout 5

Vitodens 200-W, WB2B with...

- DHW storage tank
- one heating circuit with mixing valve
- one heating circuit without mixing valve and low-loss header

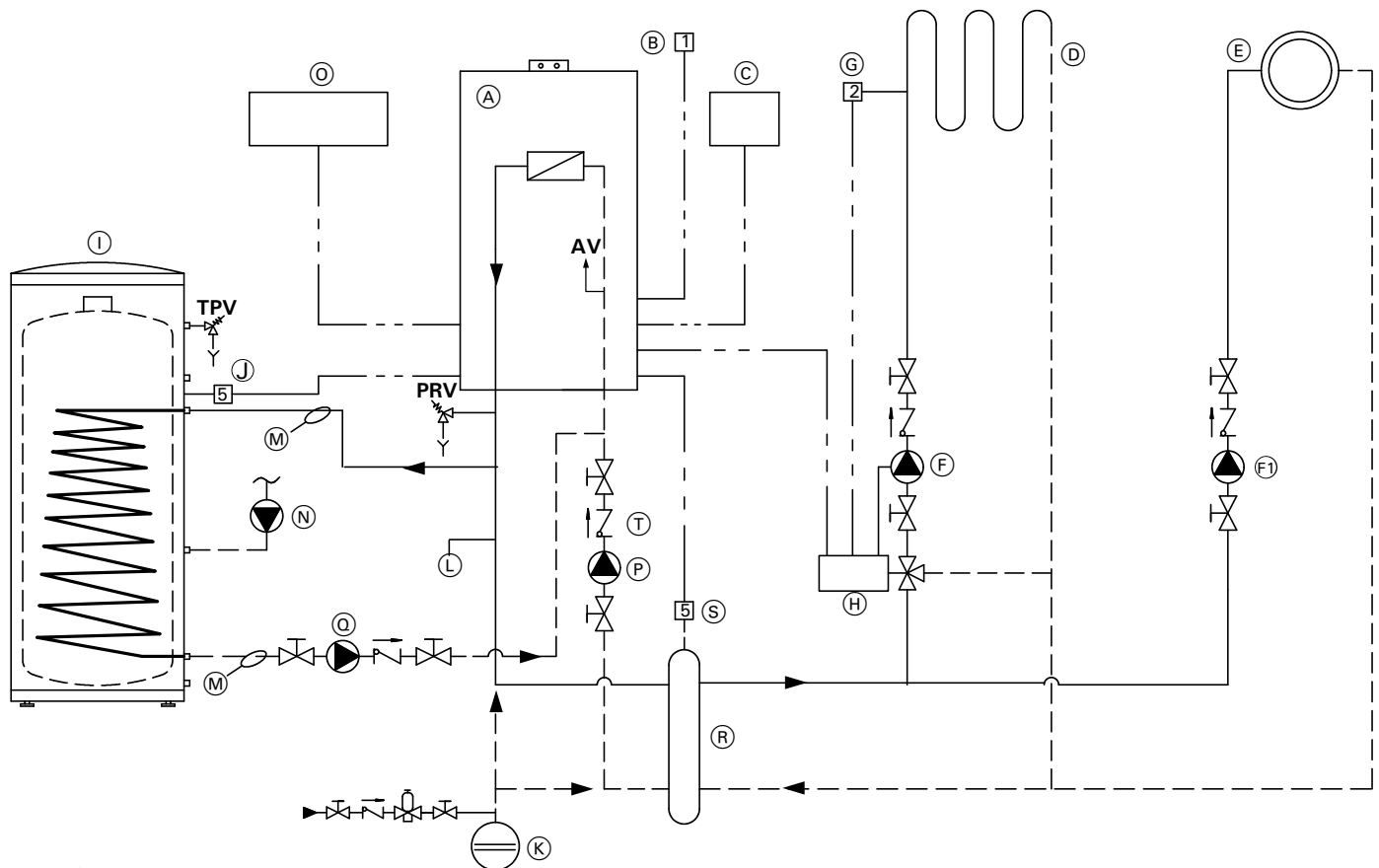

Fig. 48

Legend

- AV** Air vent (WB2B models 19 to 60 only)
- PRV** Pressure relief valve
- TPV** Temperature and pressure relief valve
- (A)** Vitodens 200-W WB2B boiler with Vitotronic 200, HO1 outdoor reset control
- (B)** Outdoor temperature sensor [1]
- (C)** Remote control Vitotrol 300 (optional)
- (D)** Under floor heating circuit
- (E)** Radiator heating circuit
- (F)** Heating circuit pump [20A]
- (F)** Heating circuit pump
- (G)** Mixing valve temperature sensor [2]
- (H)** Kit for heating circuit with mixing valve
- (I)** Domestic hot water storage tank
- (J)** DHW tank temperature sensor [5]
- (K)** Expansion tank
- (L)** Optional purge tee (field supplied)
- (M)** DHW supply and return piping
- (N)** DHW circulating pump [28]

- (O)** DHW circulating pump [21]
- (R)** Low-loss header
- (S)** Viessmann temperature sensor for low-loss header [5]
- (T)** Flow check valve

Installation of different heating circuits...

- radiator heating circuit (high-temp. circuit)
- under floor heating circuit with 3-way mixing valve (low-temp. circuit)
- DHW production

... with the following flow conditions:

The total flow rate of the two heating circuits is **greater** than the maximum possible water flow rate of the Vitodens 200-W WB2B boiler (see page 11 for maximum water flow rate of boiler). The use of a low-loss header is strongly recommended. The low-loss header is available as accessory part.

The 3-way mixing valve, built-in to achieve the low-temperature level of the under floor heating circuit, is controlled by an accessory kit for a heating circuit with mixing valve.

IMPORTANT

Please note location of expansion tank (K) and flow check valve (T).

IMPORTANT

DHW circulating pump (O) must pump into the Vitodens 200-W WB2B boiler (as illustrated).

Installation Examples

System Layout 6

Vitodens 200-W, WB2B with...

- DHW storage tank
- two heating circuits with a mixing valve and low-loss header

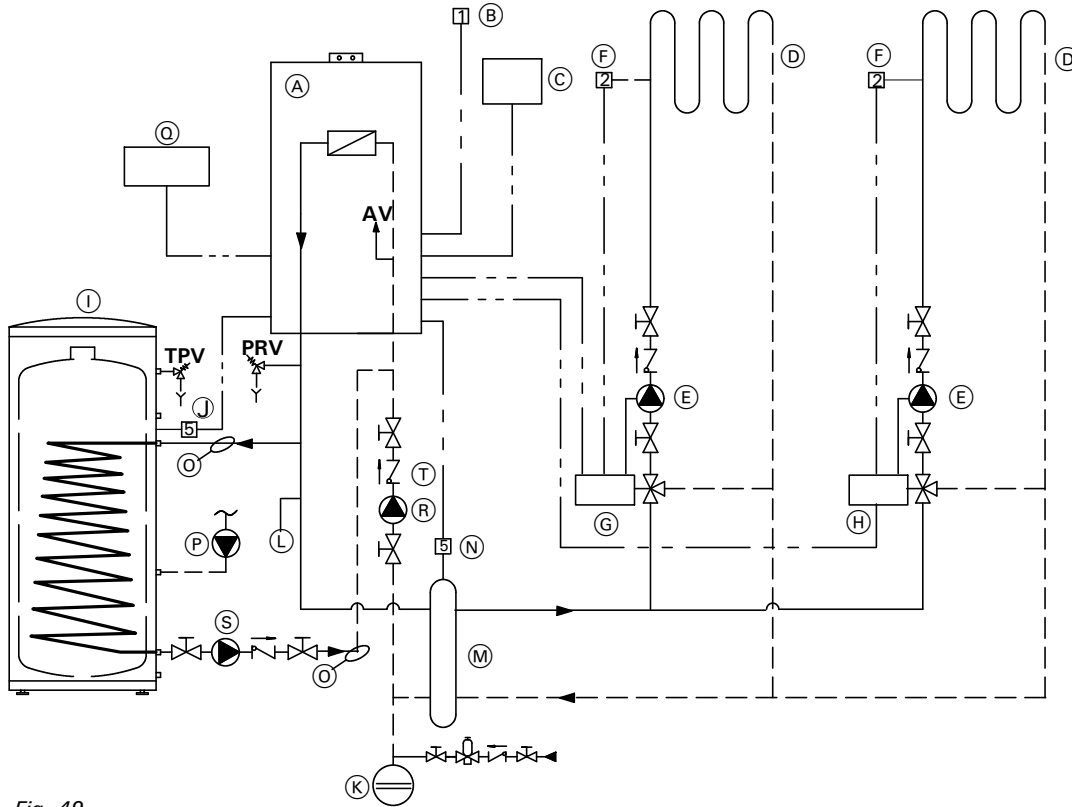

Fig. 49

Legend

- AV** Air vent (WB2B models 19 to 60 only)
- PRV** Pressure relief valve
- TPV** Temperature and pressure relief valve
- (A)** Vitodens 200-W WB2B boiler with Vitotronic 200, HO1 outdoor reset control
- (B)** Outdoor temperature sensor [1]
- (C)** Remote control Vitotrol 300 (optional)
- (D)** Under floor heating circuit
- (E)** Heating circuit pumps
- (F)** Mixing valve temperature sensor [2]
- (G)** Accessory kit for heating circuit with mixing valve
- (H)** Vitotronic 200-H, HK1M with LON communication module *1
- (I)** DHW storage tank
- (J)** DHW tank temperature sensor [5]
- (K)** Expansion tank
- (L)** Optional purge tee (field supplied) for easier air removal
- (M)** Low-loss header
- (N)** Viessmann temperature sensor for low-loss header [5]
- (O)** DHW supply and return piping
- (P)** DHW circulating pump [28]
- (Q)** Power/Pump Module
- (R)** Boiler pump [20]

- (S)** DHW circulating pump [21]
- (T)** Flow check valve

Installation of different heating circuits...

- two heating circuits with 3-way mixing valve (low-temp. circuit)

■ DHW production

... with the following flow conditions:

The total flow rate of the two heating circuits is **greater** than the maximum possible water flow rate of the Vitodens 200-W WB2B boiler (see page 11 for maximum water flow rate of boiler).

The use of a low-loss header is strongly recommended. The low-loss header is available as accessory part.

The 3-way mixing valve, built-in to achieve the low-temperature level of the under floor heating circuit, is controlled by an accessory kit for a heating circuit with mixing valve (G). The second under floor heating circuit is supplied by a field supplied circulation controlled by an accessory kit or a Vitotronic 200-H, HK1M mixing valve

control (H). If more than two heating circuits with mixing valves are to be connected, they can be controlled by a Vitocontrol multi-boiler control. Contact your local Viessmann Technical Sales Representative for details.

*1 Requires...

- LON communication module 200-H HK1M
- Boiler LON communication module
- LON cable
- End resistors

IMPORTANT

Please note location of expansion tank (K) and flow check valve (T).

IMPORTANT

DHW circulating pump (S) must pump into the Vitodens 200-W WB2B boiler (as illustrated).

System Layout 7

Vitodens 200-W, WB2B with...

- direct-connected heating circuit
- one heating circuit with system separation

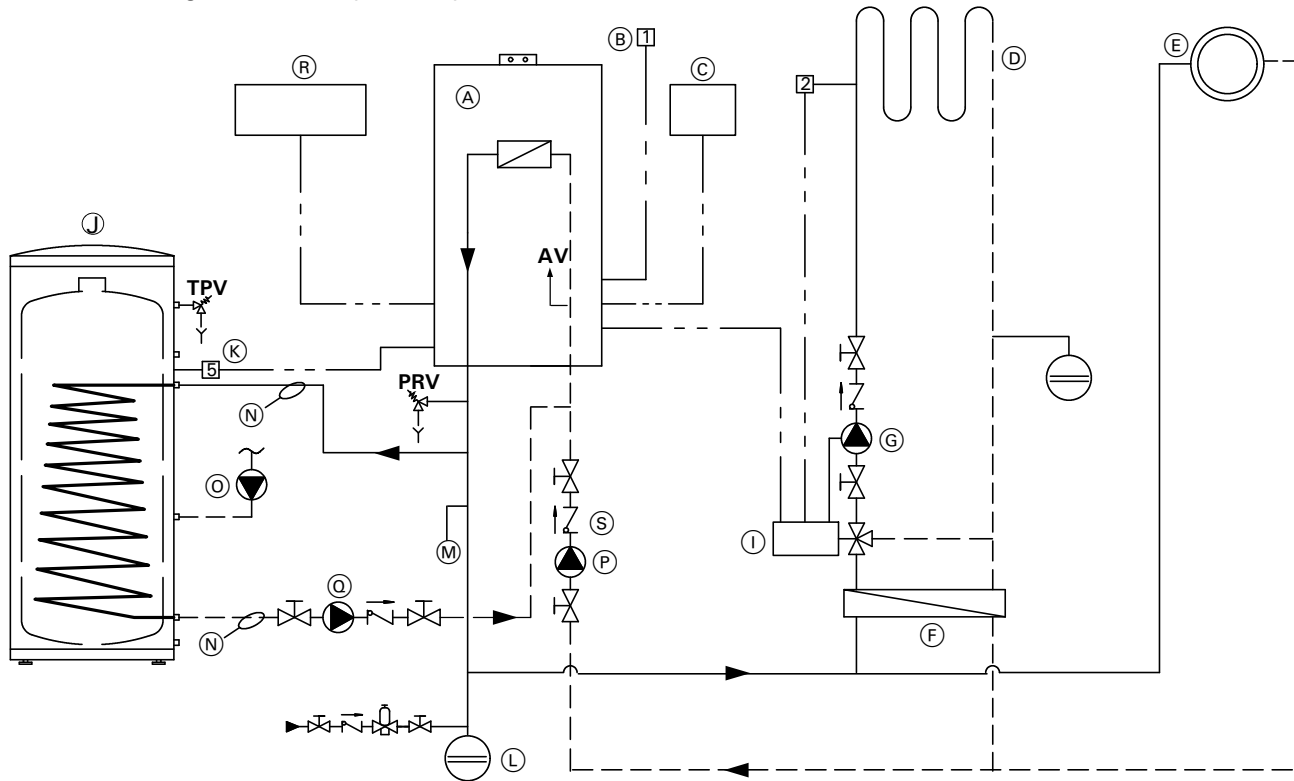

Fig. 50

Legend

- AV** Air vent (WB2B models 19 to 60 only)
- PRV** Pressure relief valve
- TPV** Temperature and pressure relief valve
- (A)** Vitodens 200-W WB2B boiler with Vitotronic 200, HO1 outdoor reset control
- (B)** Outdoor temperature sensor [1]
- (C)** Remote control Vitotrol 300 (optional)
- (D)** Under floor heating circuit
- (E)** Heating circuit pump
- (F)** Plate heat exchanger for system separation
- (G)** Heating circuit pump
- (H)** Mixing valve temperature sensor [2]
- (I)** Accessory kit for heating circuit with mixing valve
- (J)** DHW storage tank
- (K)** DHW tank temperature sensor [5]
- (L)** Expansion tanks
- (M)** Optional purge tee (field supplied)
- (N)** DHW supply and return piping
- (O)** DHW recirculation pump [28]
- (P)** Boiler pump [20]
- (Q)** DHW circulating pump [21]
- (R)** Power/pump module
- (S)** Flow check valve

Installation of different heating circuits...

- radiator heating circuit (high-temp. circuit)
- under floor heating circuit with 3-way mixing valve (low-temp. circuit)
- DHW production

... with the following flow conditions:
 The total flow rate of the two heating circuits is **less** than the maximum possible water flow rate of the Vitodens 200-W WB2B boiler (see page 11 for maximum water flow rate of boiler).

The use of a low-loss header is strongly recommended if the maximum water flow rate in the application concerned exceeds the max. boiler flow rate, or if the system flow rates are unknown. The low-loss header is available as accessory part.

The 3-way mixing valve, built-in to achieve the low-temperature level of the under floor heating circuit, is controlled by an accessory kit for a heating circuit with mixing valve (I). The boiler pump [20] supplies the radiator heating circuit and the plate heat exchanger for system separation.

IMPORTANT

The pressure drop (secondary circuit) of the plate heat exchanger (F) must be less/equal to the pressure drop of the 3-way mixing valve. This must be taken into account when sizing the plate heat exchanger.

IMPORTANT

DHW circulating pump (Q) must pump into the Vitodens 200-W WB2B boiler (as illustrated).

Installation Examples

System Layout 8

Vitodens 200-W, WB2B with...

- DHW storage tank
- low-loss header
- multiple heating circuits with mixing valves

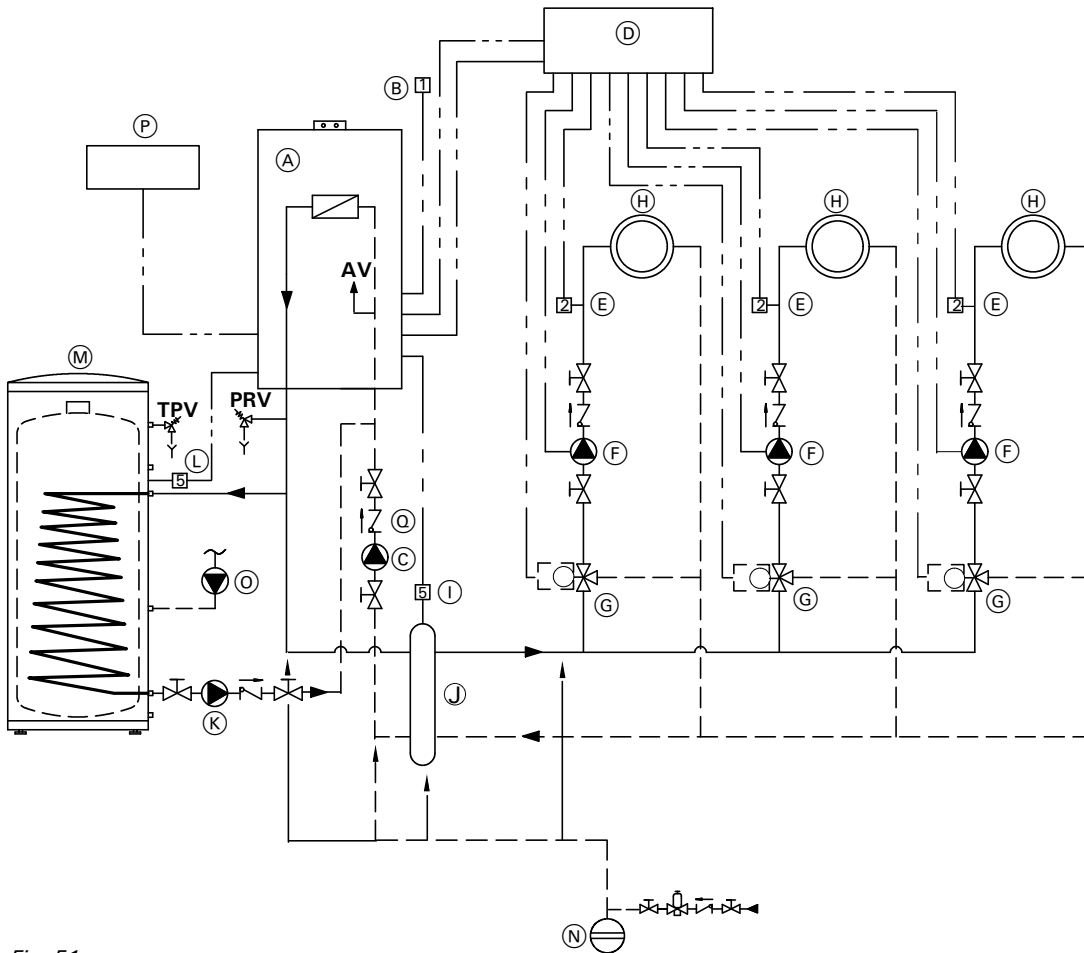

Fig. 51

When designing a system as illustrated above, please contact your local Viessmann Sales Representative for assistance.

Legend

- AV** Air vent (WB2B models 19 to 60 only)
- PRV** Pressure relief valve
- TPV** Temperature and pressure relief valve
- (A) Vitodens 200-W WB2B boiler with Vitotronic 200, HO1 outdoor reset control
- (B) Outdoor temperature [1]
- (C) Boiler pump [20]
- (D) Vitocontrol or Vitotronic 200-H, HK1S*1
- (E) Mixing valve temperature sensor [2]
- (F) Heating circuit pumps
- (G) Accessory kit for heating circuit with mixing valve *2
- (H) Heating circuits with mixing valves
- (I) Viessmann temperature sensor for low-loss header [5]
- (J) Low-loss header
- (K) DHW circulating pump [21]
- (L) DHW tank temperature sensor [5]

- (M) DHW storage tank
- (N) Expansion tank
- (O) DHW recirculation pump [28]
- (P) Power/Pump module
- (Q) Flow check valve

*1 Contact your local Sales Representative for details.

*2 Vitotronic 200-H, HK1M mixing valve control with LON communication module can be used instead of the accessory kit and Vitocontrol.

IMPORTANT

Please note location of expansion tank (N) and flow check valve (Q).

IMPORTANT

Pumps (C) and (K) must pump into the Vitodens 200-W WB2B boiler (as illustrated).

System Layout 9

Multiple (up to four) Vitodens 200-W, models WB2B 45 to 105 with...

- multiple heating circuits with mixing valves
- low-loss header

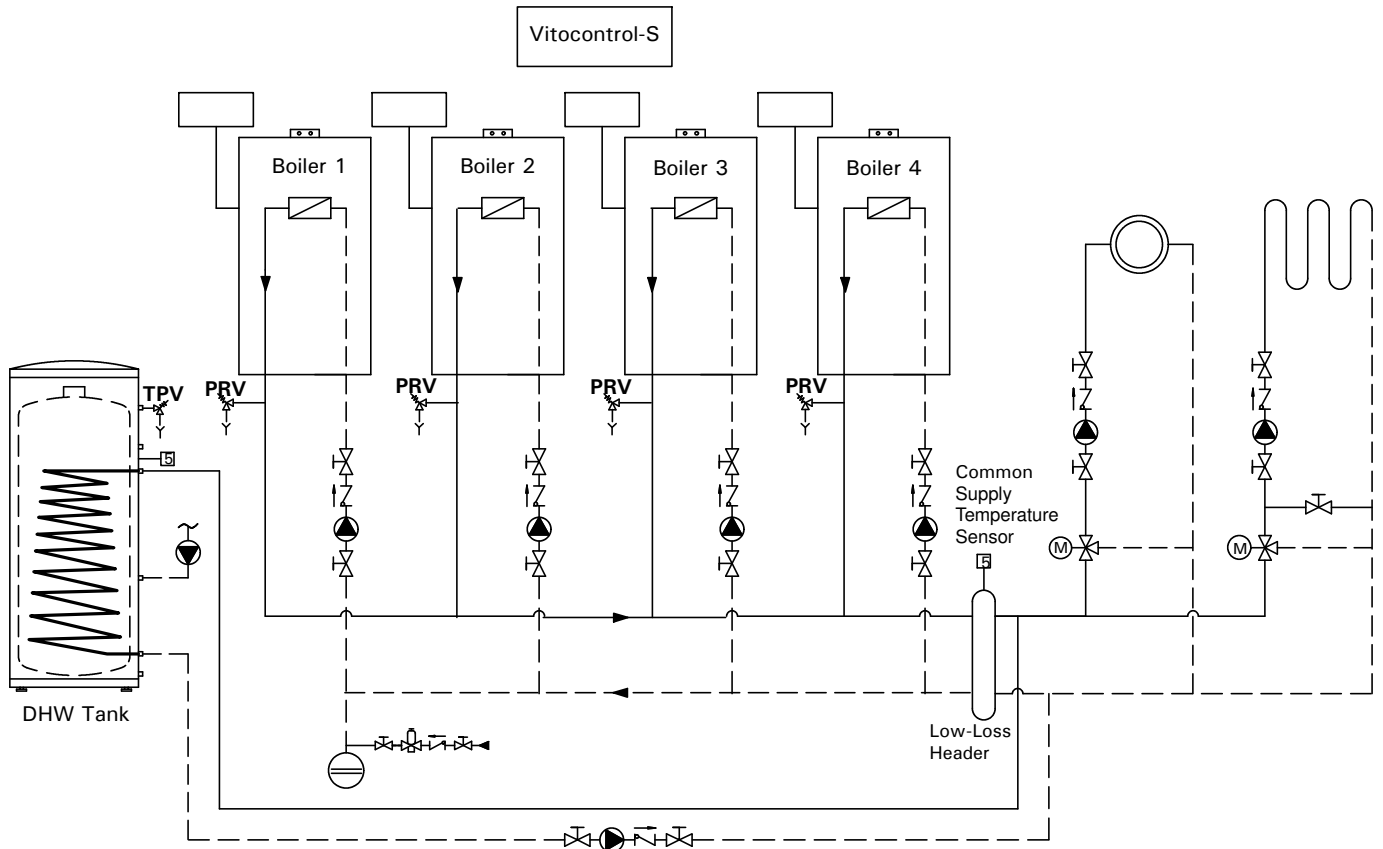

Fig. 52

When designing a multiple Vitodens system as shown above, please reference applicable multiple Vitodens technical documentation, and contact your local Viessmann Sales Representative for further assistance.

IMPORTANT

This installation example depicts a possible piping layout for multiple Vitodens 200-W, WB2B boilers equipped with Viessmann System Technology. Please note that this example is based on a simplified conceptual drawing only! Piping and necessary componentry must be field verified. A low water cut-off (LWCO) must be installed where required by local codes. Proper installation and functionality in the field is the responsibility of the heating contractor.

WARNING

If a DHW storage tank other than a Viessmann Vitocell 100 or 300 tank is used, the installer must verify proper operation of the Viessmann DHW tank temperature sensor with the original manufacturer of the tank. Viessmann strongly recommends the installation of a temperature tempering valve in the DHW supply line.

Installation Examples

The following piping diagram reflects an alternative connection for the DHW tank only and applies to system layouts 2, 5, 6 and 8. The boiler control pump logic function must be programmed in the Start-up/Service Instructions. .

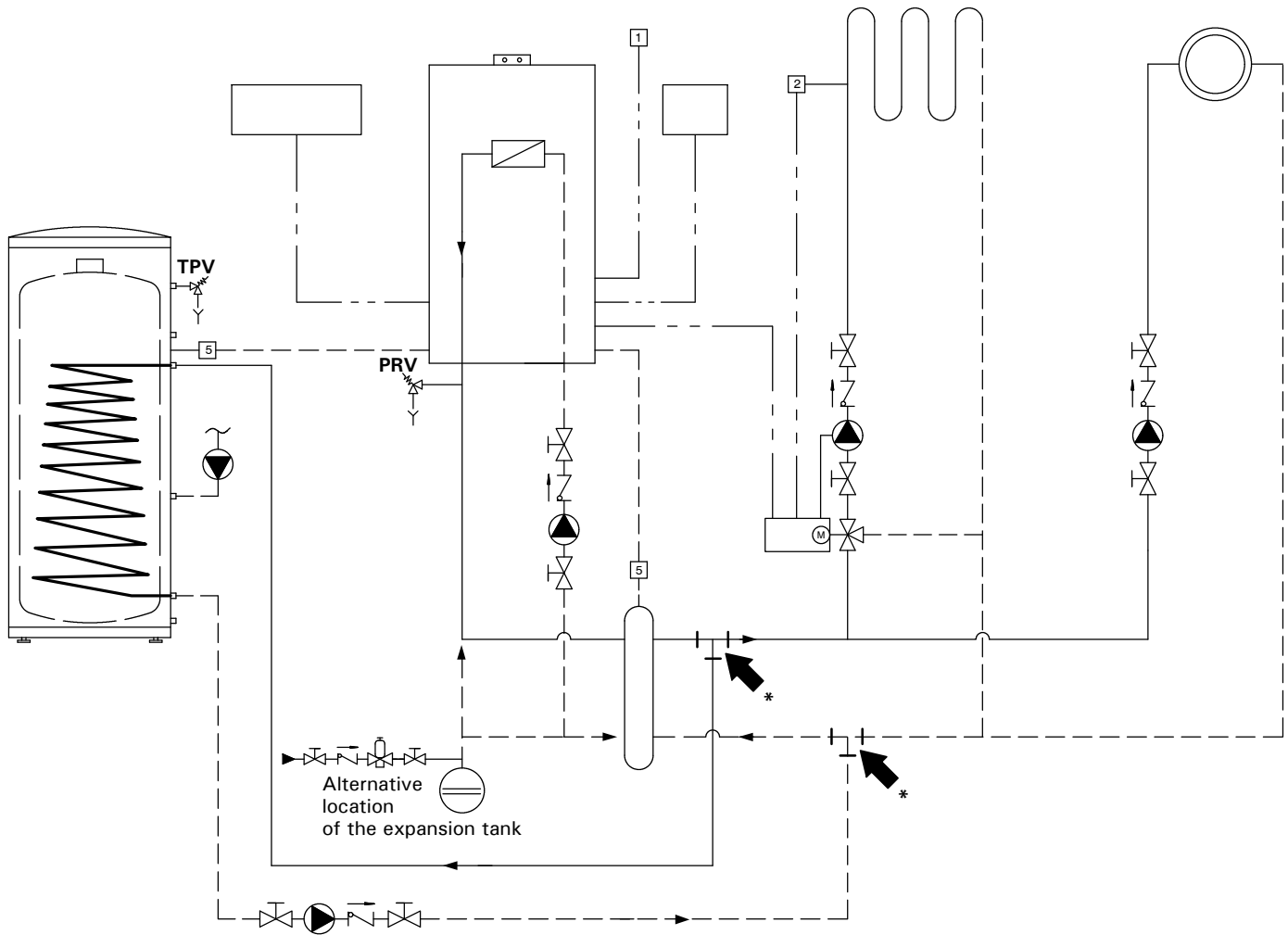

Fig. 53

***Note:**

When using a low loss header in the system, the DHW connections can be made downstream of the low loss header. See Vitodens 200-W WB2B Start-up/Service Instructions for applicable system coding information (see coding level 2):

00: ...

A2: ...

5b: ...

Overview of Electrical Connections, Models WB2B 19, 26, 35, 45 and 60

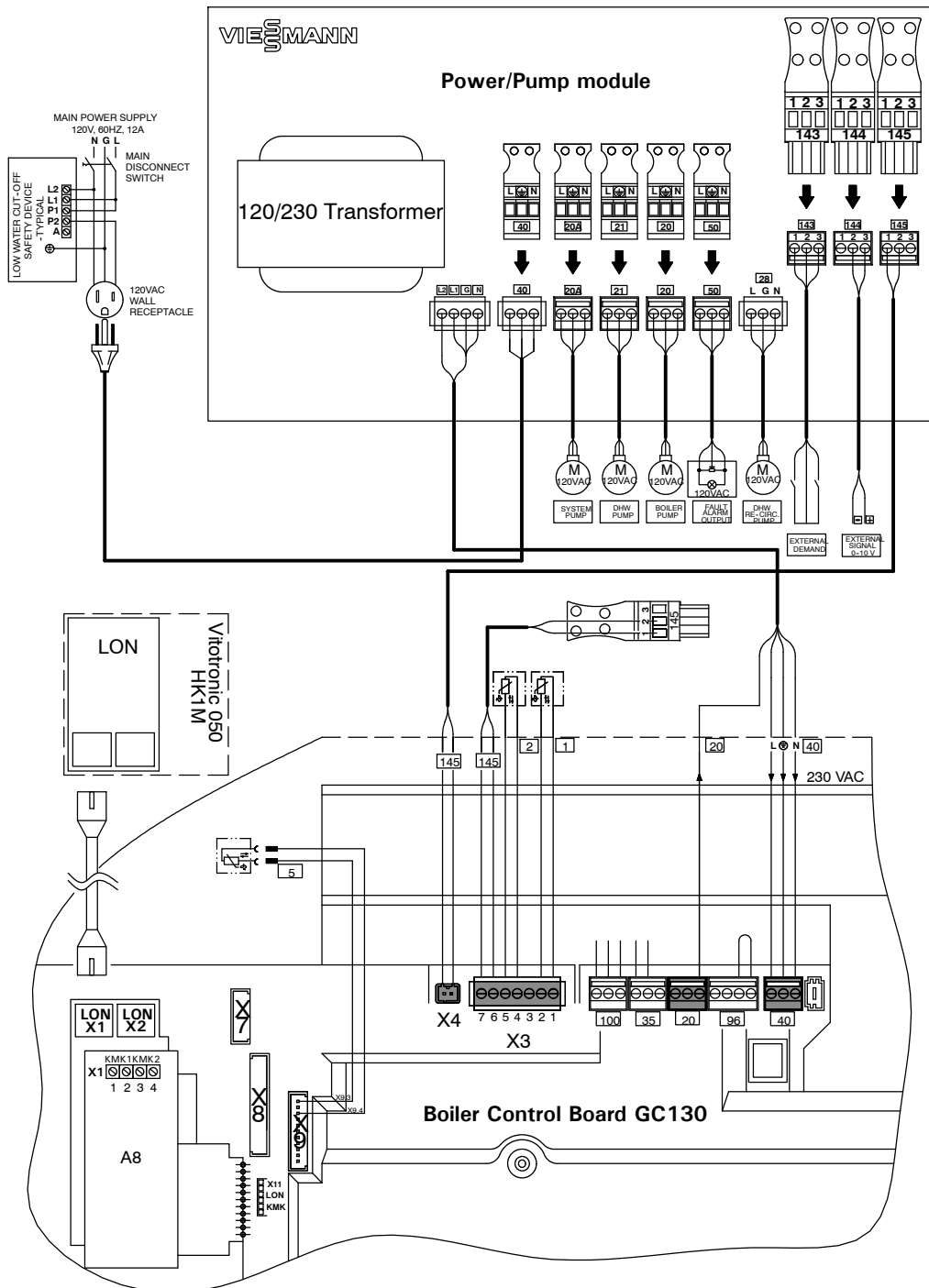

Fig. 54

Legend

- 1 Outdoor Temperature Sensor
- 2 Flow Temp. Sensor/Low-Loss Header
- 5 DHW Temperature Sensor
- 20 Boiler Pump
- 20A System Pump
- 21 DHW Pump
- 28 DHW Recirculation Pump
- 40 Power Supply

- 50 Fault Alarm Output
- 143 External Blocking Terminals 2-3
- External Demand Terminals 1-2
- External Heating Program
- Changeover Terminals 1-2 (Allocation of this function is set via Coding Address 91.)
- 144 External 0-10 V Signal
- 145 KM BUS to Power/Pump Module / Accessories

- L Low water cut-off (field supplied)
- M Power/Pump Module
- A1 Main PCB (GC130 Ignition Module)
- A6 Coding Card
- A7 Connection Adaptor
- A8 LON/Cascade Communication Module(Accessory)
- X Electrical Interfaces

Wiring Diagram

Overview of Electrical Connections, Models WB2B 80 and 105

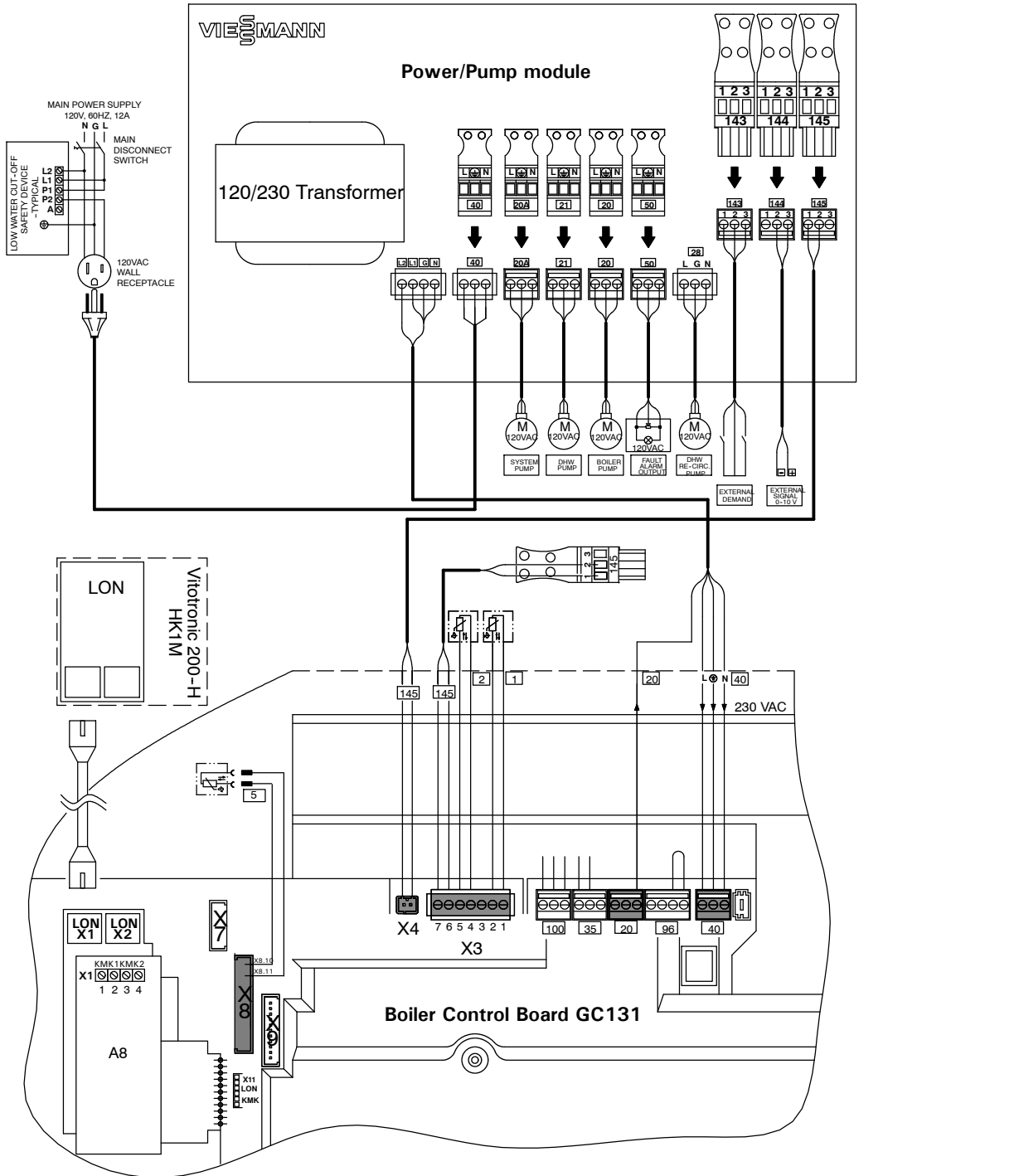

Fig. 55

Legend

- | | | | | | |
|-----|-----------------------------------|-----|---|----|--|
| 1 | Outdoor Temperature Sensor | 50 | Fault Alarm Output | Ⓛ | Low water cut-off (field supplied) |
| 2 | Flow Temp. Sensor/Low-Loss Header | 143 | External Blocking Terminals 2-3 | Ⓜ | Power/Pump Module |
| 5 | DHW Temperature Sensor | | External Demand Terminals 1-2 | A1 | Main PCB (GC131 Ignition Module) |
| 20 | Boiler Pump | | External Heating Program Changeover Terminals 1-2 (Allocation of this function is set via Coding Address 91.) | A6 | Coding Card |
| 20A | System Pump | 144 | External 0-10 V Signal | A7 | Connection Adaptor |
| 21 | DHW Pump | 145 | KM BUS to Power/Pump Module / Accessories | A8 | LON/Cascade Communication Module (Accessory) |
| 28 | DHW Recirculation Pump | | | X | Electrical Interfaces |
| 40 | Power Supply | | | | |

System Design Considerations

IN THE COMMONWEALTH OF MASSACHUSETTS...

-this product shall be installed by a licensed plumber or gas fitter.

-the flexible connector (if used) cannot exceed 36".

-any level type shutoff used must be of tee handle type.

Boiler location

As a direct vent appliance, the Vitodens 200-W can be installed for room air independent operation (sealed combustion) **regardless** of size and ventilation method of the room in which it is located.

The Vitodens 200-W can be installed, for example, in the main living area of a house, in non-ventilated utility rooms, cupboards, closets and alcoves with no clearance required from combustible materials, as well as in attics with a direct outlet for the flue gas/fresh air system. Follow all local and national codes.

Flue gas system

Viessmann PPS (Polypropylene) concentric flue gas/fresh air systems for room air independent operation (sealed combustion) and side wall venting are tested to ANSI Z21.13 - CSA 4.9 - 2000 standards and are certified together with the Vitodens 200-W boiler as a constructional unit.

The Vitodens 200-W boiler may also be vented vertically, using an AL29-4C® special stainless steel, single-wall, room air dependent venting system (UL listed for category IV).

For a more detailed description of the direct vent and single-wall vent system, please refer to the Vitodens 200-W Venting System Installation Instructions.

Flue gas temperature protection

Flue pipes used for the Vitodens 200-W are suitable for max. flue gas temperatures of up to 230°F / 110°C.

No flue gas temperature protection is required as the maximum permissible flue gas temperature is not exceeded in any operating condition or in the event of malfunctioning.

Low water cut-off

A low water cut-off may be required by local codes. If the boiler is installed above the radiation level, a low water cut-off device of approved type must be installed in all instances. An approved type low water cut-off device must be provided by the heating contractor. Do not install an isolation valve between the boiler and the low water cut-off.

System layout

■ The max. boiler water temperature for space heating and DHW production is –165°F / 74°C for models WB2B 19 to 60 or –176°F / 80°C for models WB2B 80 and 105.

To minimize distribution losses, Viessmann recommends that the heating and domestic hot water systems be based on a maximum boiler supply temperature of 158°F / 70°C.

■ Due to the low return temperatures required for gas condensing, no mixing valves should be used in the heating circuit whenever possible. If mixing valves are required, e.g. for multi-circuit systems or underfloor heating systems, only 3-way mixing valves must be used.

Do not use 4-way mixing valves with condensing boilers.

Water connections

Vitodens 200-W boilers can be used in any fully pumped hot water heating system. Minimum system pressure is 0.8 bar/12 psig.

Chemical corrosion protection products

Corrosion does not typically occur in sealed heating systems which have been correctly installed and are correctly operated.

Many manufacturers of plastic pipes recommend the use of chemical additives. In this case, only those commercially available corrosion protection products approved for boilers with domestic hot water heating via single-wall heat exchangers (instantaneous plate heat exchangers or DHW tanks) must be used.

Underfloor heating systems

For underfloor heating systems Viessmann recommends the use of plastic tubing with an oxygen diffusion barrier in order to prevent the diffusion of oxygen through tubing. If plastic tubing without an oxygen diffusion barrier is used in underfloor heating systems, Viessmann recommends that such systems be separated from the boiler with a heat exchanger.

Underfloor heating systems and heating circuits containing a very large volume of water must be connected to the boiler via a 3-way mixing valve; please refer to the applicable installation example in this manual.

Oxygen diffusion barrier underfloor tubing

The boiler warranty does not cover leaks resulting from corrosion caused by the use of underfloor plastic tubing without an oxygen diffusion barrier. Such systems must have the non-oxygen diffusion barrier tubing separated from the boiler with a heat exchanger. Viessmann recommends the use of underfloor plastic tubing with an oxygen diffusion barrier.

Water quality

Treatment for boiler feed water should be considered in areas of known problems, such as where a high mineral content and hardness exist. In areas where freezing might occur, an antifreeze may be added to the system water to protect the system. Please adhere to the specifications given by the antifreeze manufacturer. Do not use automotive silicate based antifreeze. Please observe that an antifreeze/water mixture may require a backflow preventer within the automatic water feed and influence components such as diaphragm expansion tanks, radiation, etc. Maximum antifreeze content is 50% for the Vitodens 200-W boiler. Do **not** use antifreeze other than specifically made for hot water heating systems. System also may contain components which might be negatively affected by antifreeze. Check total system frequently when filled with antifreeze. Advise system operator/ultimate owner that system is filled with a glycol mix. The heating contractor must provide a MSDS (Material Safety Data Sheet) for the antifreeze used to the system operator/ultimate owner.

Warranty

Our warranty does not cover damages resulting from the following:

- installation or service by unqualified and unlicensed personnel.
- attempting to perform any repair work on the boiler other than that mentioned in the boiler literature.
- tampering with or attempting, without Viessmann permission, to readjust the factory settings of the
 - combination gas valve
 - combustion air opening of the burner blower

Leaks resulting from corrosion caused by the use of underfloor plastic tubing without an oxygen diffusion barrier. For detailed warranty information, please read warranty sheet supplied with product.



Viessmann Manufacturing Company (U.S.) Inc.
45 Access Road
Warwick, Rhode Island • 02886 • USA
Tel. (401) 732-0667 • Fax (401) 732-0590
www.viessmann-us.com • info@viessmann-us.com

Viessmann Manufacturing Company Inc.
750 McMurray Road
Waterloo, Ontario • N2V 2G5 • Canada
Tel. (519) 885-6300 • Fax (519) 885-0887
www.viessmann.ca • info@viessmann.ca

